BATTIPAV

MAKE YOUR ITALIAN CUT

2024

Designed and Made in Italy

Since 1983

INDEX OF CATEGORIES

LARGE FORMAT TILES TOOLS

With the advent of large-format tiles, we have designed a range of practical and innovative solutions that help installers in their day-to-day activities.

FROM pag. 16 TO 39



MANUAL TILE CUTTERS

Tile cutters are our core business, but also the part on which our R&D department works the hardest to ensure flawless daily use, from the classic to the top ones.

FROM pag. 40 TO 65

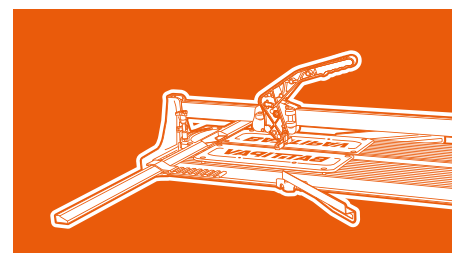

ELECTRIC MACHINES

From those perfect for marble, to those suitable for tiles, or those for blocks. Our electric machines develop on all fronts, even for cleaning or mixing.

FROM pag. 66 TO 135

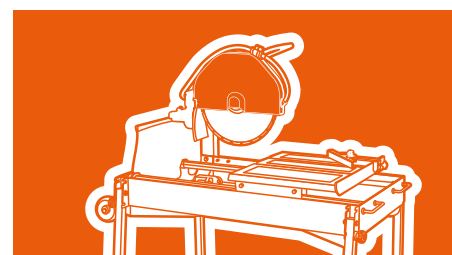

HIGH PERFORMANCE DIAMOND TOOLS

The range of discs and drills is an innovation for Battipav, which is committed to becoming a single supplier of electric machines and its discs to have everything in one solution.

FROM pag. 136 TO 139



SUBMERSIBLE PUMPS

We are the only manufacturers of exclusively Made In Italy submersible pumps. They are designed with great attention to durability and performance, customized for each machine.

FROM pag. 140 TO 143

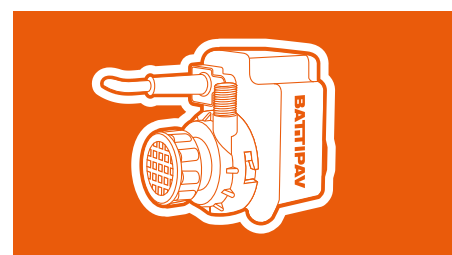

SELF LEVELING AND TOOLS

From trowels and mallets to spare parts, spacers and sponges. Battipav can provide everything you need to bring the world of tilers everything they need.

FROM pag. 144 TO 148

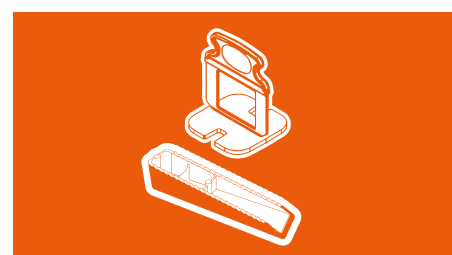

INDEX OF CONTENTS

LARGE FORMAT TILES TOOLS

Lampo Cut	Pag. 18
Multi Bench	Pag. 20
Mini Multi Bench	Pag. 22
Agile Light Plus	Pag. 24
Agile Light	Pag. 26
Compact Light Plus	Pag. 28
Compact Light	Pag. 30
Cargo	Pag. 32
Perfect Jolly	Pag. 34
Suction Cup	Pag. 36
Pulse	Pag. 38

MANUAL TILE CUTTER

Sintesi	Pag. 42
Profi Evo	Pag. 46
Leggera	Pag. 50
Super Pro Evo	Pag. 54
Super Pro	Pag. 58
Basic Plus	Pag. 62

ELETTRIC MACHINES

Prime 700	Pag. 68
Expert	Pag. 72
Elite 80	Pag. 76
Ego Plus	Pag. 80
Prime	Pag. 84
Supreme	Pag. 88
Dynamic	Pag. 94
Extra 3300 S Superlunga	Pag. 98
Class Plus	Pag. 102
Class	Pag. 106
Vip	Pag. 110
Queen 180	Pag. 114
Tools For Better Performance	Pag. 116
Mixer	Pag. 118
Mixit	Pag. 122
Mini Mix	Pag. 126
Master Linda	Pag. 128
Linda Veloce	Pag. 132

HIGH PERFORMANCE DIAMOND TOOLS

Diamond Discs	Pag. 136
Drill Bits	Pag. 138
Grinder Bits	Pag. 138

SUBMERSIBLE PUMPS

Submersible Pumps	Pag. 140
-------------------	----------

TOOLS

TT-Level	Pag. 144
Tools	Pag. 146

SPECIAL VOLTAGES & NOTE

Oceania	Pag. 149
Switzerland	Pag. 149
Saudi Arabia And U.A.E.	Pag. 149
United Kingdom	Pag. 150
Central And Nord America	Pag. 151
Notes	Pag. 152



**BATTIPAV
CATALOGUE 2024**

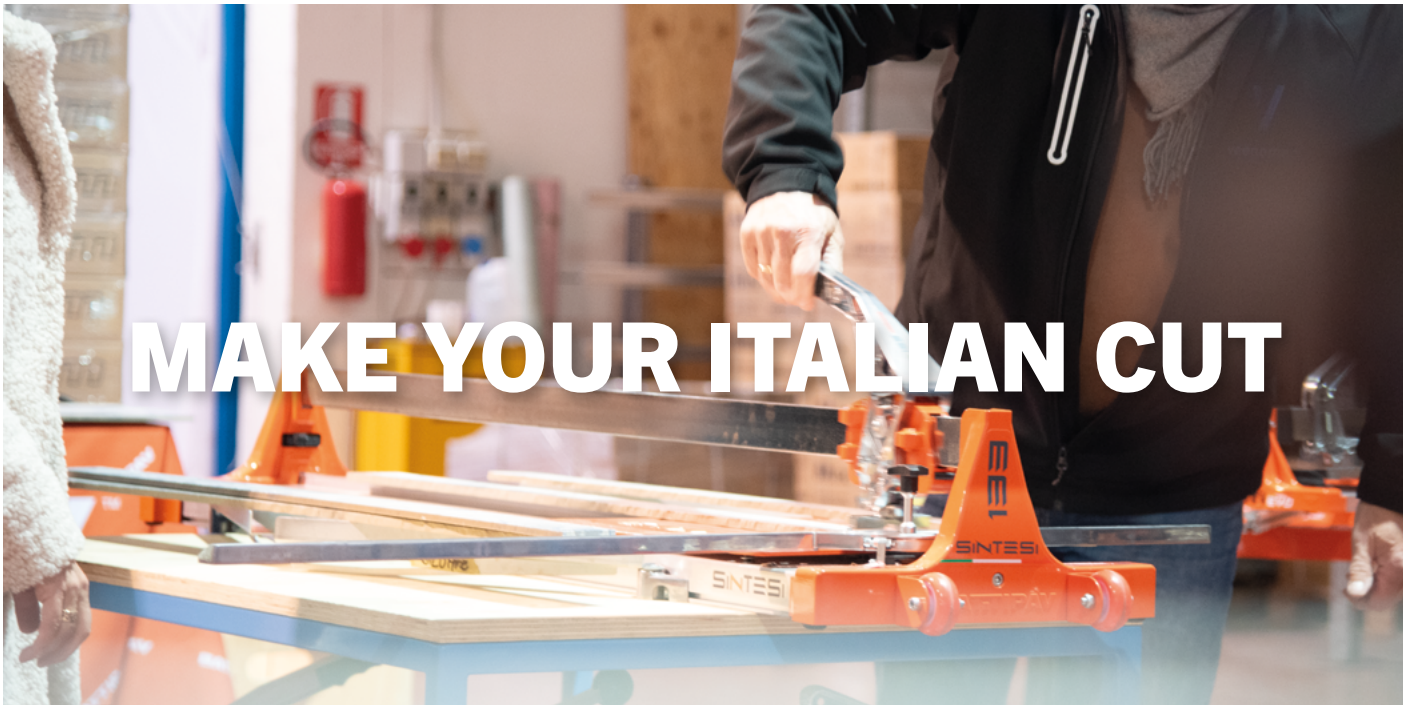

MAKE YOUR ITALIAN CUT

A Success Story

"Getting together is a beginning, staying together is progress, working together is success." Henry Ford.

As Ford said, the success is working together and the story of **Battipav** is a **success story**. Battipav was born when Claudio Tondini and his wife Ketty Arlati decided to start their entrepreneurial career.

This dream continues to stand, solid, prolific and with a large dose of quality, growing and innovating every year.



Industrial evolution

Battipav began as a small company producing roller tile beaters for leveling ceramic tiles on floors.

Through the years, Battipav has grown, expanding and becoming a leading company in the creation of both **cutting machines** and **submersible pumps**.

Later, thanks to Stefano Tondini, son of the founders, the **company has gone digital**, becoming one of the first companies in the sector to have an **in-house marketing department** and a strong focus on **welfare**.

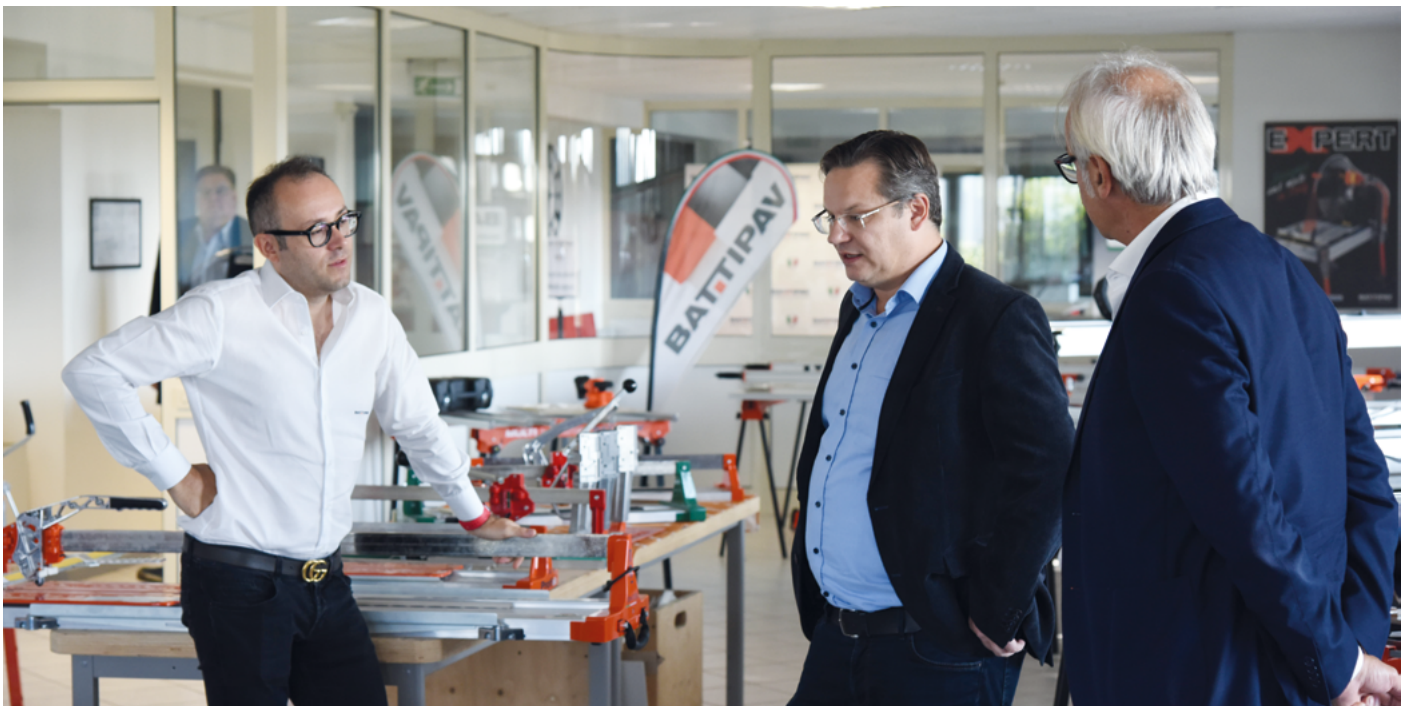

Quality and Respect

Innovation, evolution and continuous development are the main traits of **Battipav's vision**, which aims to be the **Best Partner** of every professional in the construction industry, able to offer the best technical solutions **Made in Italy**.

Paying attention to Quality is a guiding light: we always look for the best solution for the specific engine, machine, cut or product.

In a world full of consumerism, Battipav chooses to go against the trend: **our machines are products built to last**.



Training and Experience

Not only production of machines for buildings, but **training** with our #BattipavAcademy or free **practicing session** at our headquarters #VisitBattipav: these are Experiences that connect us by sharing moments together.

You can also always count on the **support of our Marketing department** to ensure brand and product promotion: all of this means being part of the Battipav World.

PRECISE PRODUCTS, OUTSTANDING SERVICE, MADE IN ITALY



FAST LEG



SPRAY SYSTEM



W-DEC

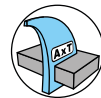

AXT



TT-POWER

System that ensures rigidity and steadiness and allows to stack up to 3 machines on one pallet. It was designed to reduce overall dimensions during transport and above all the storage space.

It works on the vital points of the diamond tool, reducing cutting dust. This system improves the life of the diamond tool, by creating a flow of misty water inside the blade guard.

The original shape of the water tray prevents the grout to accumulate in the pump area, allowing the pump to always use clean water.

This trademark represents the winning association as submersible pump and masonry saw. The trademark symbolizes originality and high quality.

Designed inside our Research & Development of our machines. Every part is assembled and tested by our technical staff.

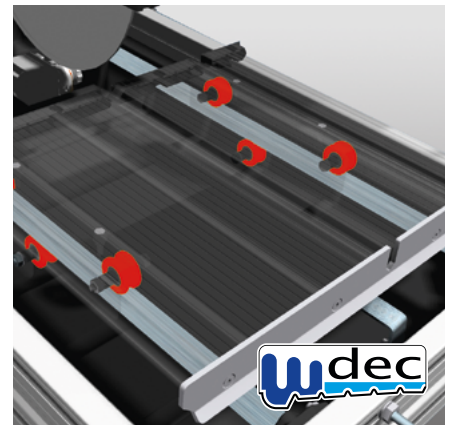
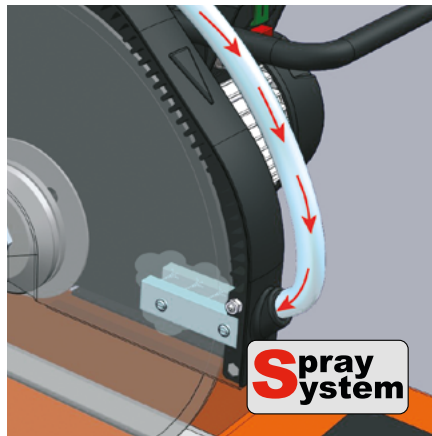

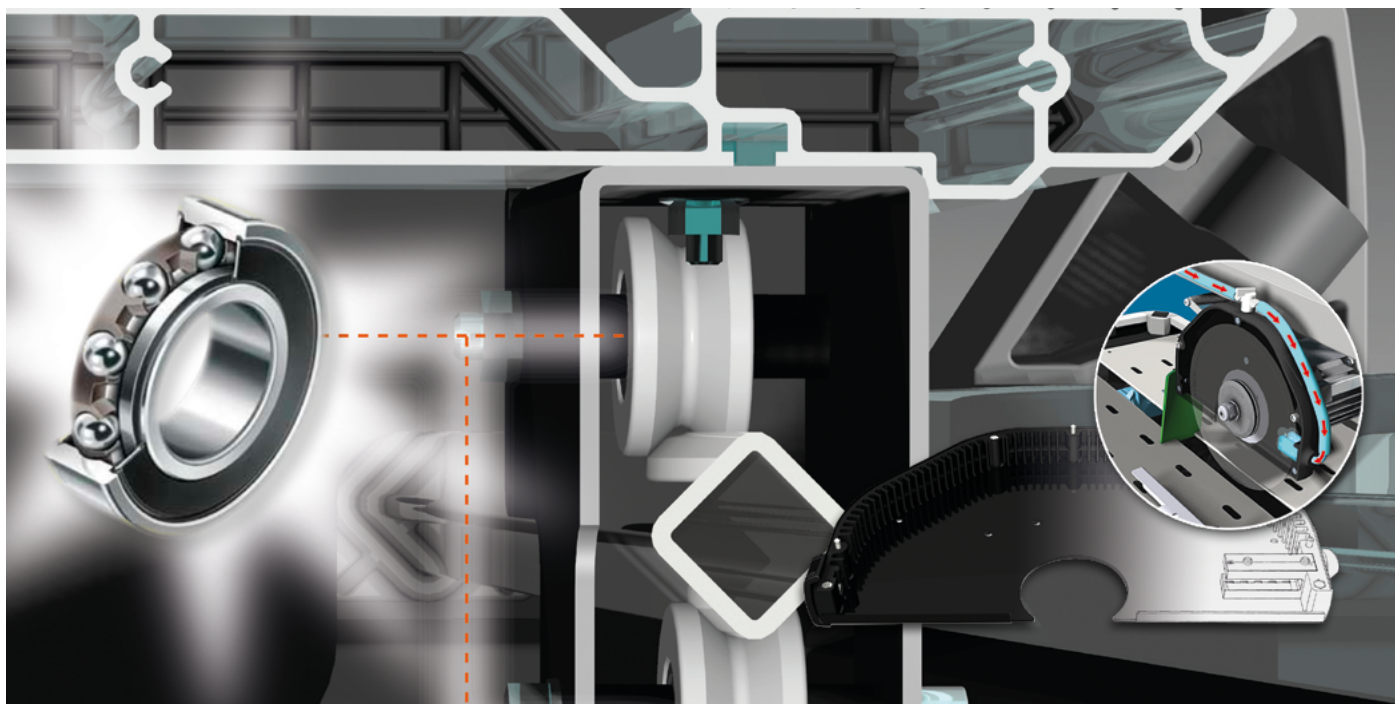

Technology aiming to Precision

All our machines are extremely precise:

all the carriages, from manual tile cutters to sliding tables and motor supports are equipped with steel ball bearings in order to guarantee the highest precision, the smoothest movement and a long life.



Design Philosophy

Battipav is proud to design, develop and manufacture the most important components of any electric saw and manual tile cutter, **inside their factory.**

From the electric motor, designed according to the specific needs of the machines in which it is to operate, to the frame, patented and made of innovative extruded aluminum, which makes it light but at the same time solid, to the submersible pumps completely produced in-house.

BATTIPAV *Design Philosophy*

Battipav is proud to design, develop and manufacture the most important components of any electric saw and manual tile cutter, inside their factory.

Spray System

Prevents cutting dust and improves the life of the diamond tool, by creating a flow of misty water inside the blade guard.

Electric Motor

Designed inside our Research & Development Dept., according to the specific requirements of our machines. Every part is assembled and tested by our technical staff.

Pump

Professional pump for diamond blade cooling. It is fully manufactured inside our factory.

Fast Leg

It was designed to reduce overall dimensions during transport and above all the storage space.

Water Tray

The original shape of the water tray prevents the grout to accumulate in the pump area, allowing the pump to always use clean water.

Frame

Patented, made of innovative extruded aluminium, according to the requirements of , very solid and rigid.



BATTIPAV *Quality Controls*

Strict quality control on chosen materials and tests carried out on our products enable us to offer a 2 years guarantee against faults of materials and manufacture. The following are not included in the guarantee: faults due to incorrect use, normal wear and tear of materials, and incorrect maintenance.



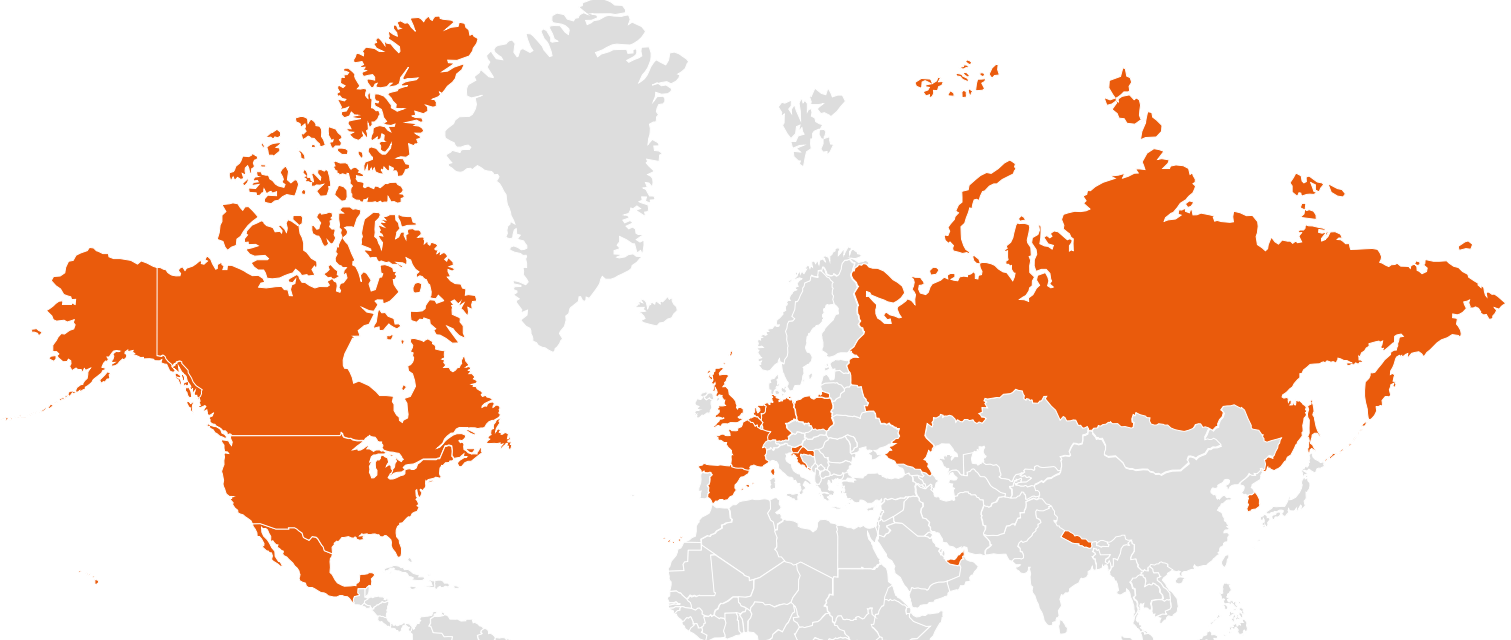

BATTIPAV Ambassador

Battipav is not just a company but is a world. By becoming Ambassador, we will be supporting you through all the business, from the technical training to the dedicated initiatives, from the marketing material to the social networks. You can also experience unique emotions by participating in adrenaline-pumping events and living the MotoGP Paddock. Find out how to become an Ambassador and experience the Battipav life!

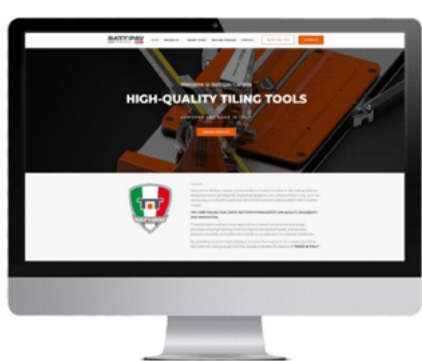



BATTIPAV Experience

LIVE THE BATTIPAV EXPERIENCE!

Battipav makes you live the adrenaline inside the MotoGP Paddock with the Gresini Racing Team. By becoming a Battipav Ambassador you will be part of an amazing Made In Italy sport project. We have chosen Gresini Racing Team for the strong shared values of territoriality, quality, family and friendship. Don't miss this opportunity!



BATTIPAV Academy

You will have the opportunity to take advantage of free training needed to promote all products, either by going into detail through online training or by coming to our headquarter to try out our tiles.



Battipav chooses Innovation.

It has been a couple of years now that the manuals are no longer printed. You just scan the QR CODE you will find on the machine or its packaging and find everything you need: from the manual, to the video and more.

JUST FOLLOW THIS LABEL :)   User Manual



1 SCAN THE QR CODE

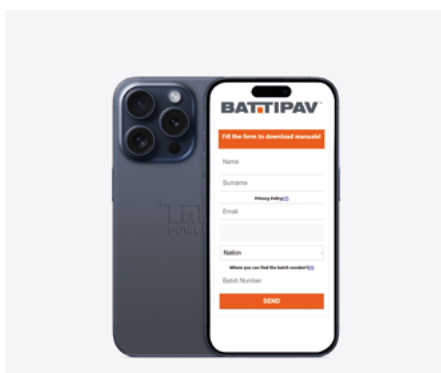

2 FILL OUT THE FORM

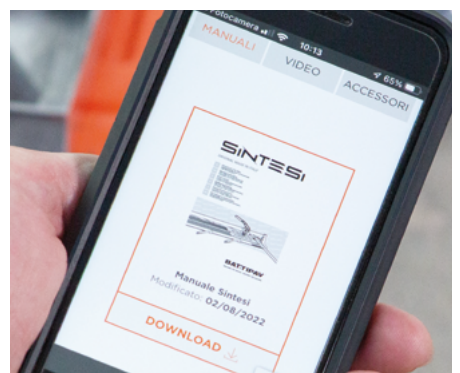

3 DOWNLOAD MATERIALS



BATTIPAV *FairKit*

Our marketing team developed some strategies, focused on the exhibition of Battipav products around the world. Discover our ideas to increase your Sales together!



Socket categories and plugs

/Machine for industrial use - 50 / 60 Hz

		230V Single-phase socket CEE IEC 309	200-250V	H6
		115V Single-phase socket CEE IEC 309	100-130V	H4
		400V Three-phase socket CEE IEC 309	380-415V	H6
		230V Three-phase socket CEE IEC 309	200-250V	H9

/Machine for civil use

		230V 50Hz Single-phase socket	SCHUKO
		230V 50Hz Single-phase socket	UK BS1363A
		230V 50Hz Single-phase socket	AUSTRALIAN AS3112
		115V 60Hz Single-phase socket	USA NEMA 5-15P



Art. SP90159
CEE SOCKET 230V with cable 3 mt. and
SCHUKO PLUG



Art. SP90159/UK
CEE SOCKET 230V with cable 3 mt.
and UK PLUG



Art. SP90159/AUS
CEE SOCKET 230V with cable 3 mt.
and AUSTRALIAN PLUG



Art. SP90259/AUS
SCHUKO SOCKET 230V with cable 3
mt. and AUSTRALIAN PLUG



Art. SP90259/UK*
*(suitable only for CLASS / CLASS PLUS
RANGE 230V with LASER+Mixer)
SHUKO SOCKET 220V. + CABLE 3
mt. + UK PLUG



Art. SP0502
Extension cable 10 mt. with plug and
SCHUKO socket.



Art. SP90159/T380
CEE SOCKET 400V with cable 3 mt.
For all the electrical machines with
three phases motor.



Art. SP90159/T380C
CEE SOCKET 400V with cable 3 mt.
CABLE 3 mt. + CEE PLUG 400V.



Art. SP0502/ACEE
Extension cable 10 mt. with CEE plug &
socket 115V.
Suitable for: Class / Class Plus with
laser / Mixer



Art. SP90259/USA
CEE SOCKET 110V with cable 2,5 mt.
and USA PLUG



Art. SP90159/T230
CEE SOCKET 230V with cable 3 mt.
for all the electrical machines with
three phases motor



Art. SP90159/A
CEE SOCKET 110V. + CABLE 3mt. +
CEE PLUG 110V.

Pictograms

	Our code reference		SHUKO plug connection
	Net weight		Tungsten carbide wheel diameter
	Pieces for pallet		Packing dimension
	Max straight cutting length		Pallet dimension
	Max size tile for diagonal cutting		Bucket capacity
	Max cutting depth for straight cut		Mixing capacity
	Max cutting depth for 45° angle cut		Diamond drill diameter
	Max cutting depth with 2 RUNS		Tank capacity
	Diamond blade diameter / Hole		Speed selector
	Amperometric protection		Cleaning width
	Power engine		Water cooled
	Rotation speed		45° angle cut (jolly)
	Three phases CEE plug connection		Cutting height adjustment
	Single phase CEE plug connection		Overlapping for storage
	Motor Type: Infinity		



**LARGE FORMAT TILE TOOLS
RANGE 2024**

BATTIPAV

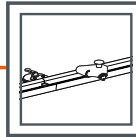

LAMPO cut

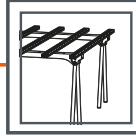

MULTI bench

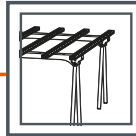

MINI MULTI
bench

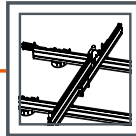

AGILE LIGHT
plus

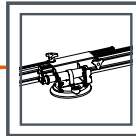

AGILE LIGHT

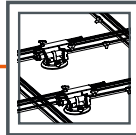

COMPACT
LIGHT PLUS

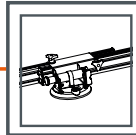

COMPACT LIGHT



CARGO



PULSE

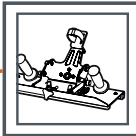

PERFECT
Jolly

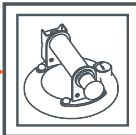

SUCTION CUP

LAMPO *cut*



WATCH NOW ▶



/Description

Lampo Cut is a simple, easy and fast solution for cutting tiles up to 3200 mm in length (it can be also extended indefinitely by purchasing separate extensions). Lampo Cut takes its name from the Italian word “LAMPO” (Lightning or Flash in English) as it is synonymous of speed. The engraved guide houses two silicone inserts to maximize the adherence to the tile during the cut.

/Equipped with

- 2 rails
- 3 Suction Cups
- 1 carriage
- 2 cutting wheels
- 1 Easy Break for tiles up to 10 mm of thickness
- 1 soft bag

/Compatible with

- Multi Bench
- Agile family
- Perfect Jolly
- Mini Multi Bench

/Also buy with

- Multi Bench
- Agile family
- Compact family
- Perfect Jolly
- Mini Multi Bench
- Easy Break
- Pulse
- Cargo

LAMPO cut

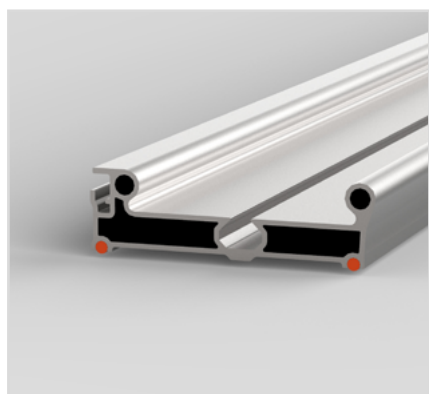

PROFILE RAIL

Special profile rail, high resistance structure with rubber inserts:

- no scratches on the surface
- more stability during the cut



CONNECTIONS

With the Joint (art. 11204) it is possible to easily connect two or more products.



CARRIAGE

It is robust and comfortable to use with 3 nylon sliding pulleys with 3 ball-bearings.

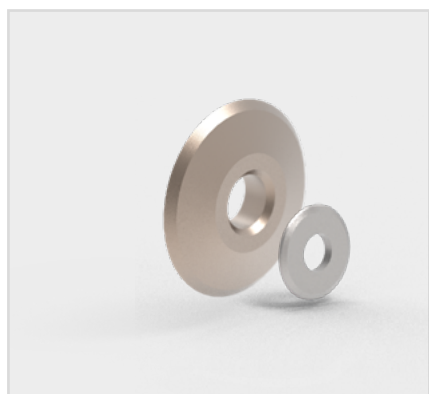

CUTTING

Supplied with 2 cutting wheels Ø 15 and 22 mm (key set included).

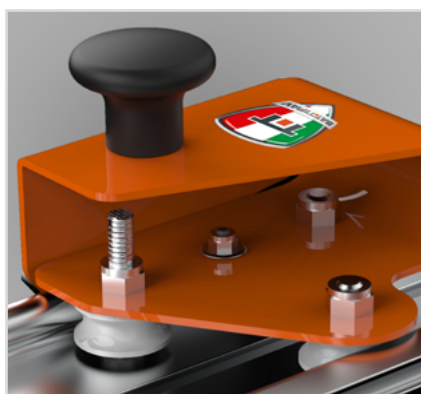

HANDLE DESIGN



A studied handle design to comfortably cut every kind of material.



SOFT CASE

Supplied with a soft case which, thanks to a pair of wheels, makes transportation easy and safe..

/Technical Info

ARTICLE	Technical info			Packaging info	
	CUTTING LENGTH	CUTTING THICKNESS WITH PLIERS (Art. 11301)	LENGTH OF THE SINGLE TRACK		
LAMPO CUT (Art. 11101/1)	3200mm	10 mm	1690mm	1800x645 x265 mm	650x1795 x2060 mm

/Price list

ARTICLE	DESCRIPTION	KG
11101/1	Lampo Cut 2 - Cutting Track For Large Size Tile With Pliers + Bag	13,3
> 2009	Kit Spare Wheel Ø15 mm	0,12
> 492	Kit Spare Wheel Ø22 mm	0,18
> 11301	Easy Break Plier For Thick Tiles	0,7
> 11129I	Soft Bag For Lampo Cut	3,5
> 11129IS	Bag for Lampo Cut - boxes 5pcs	21

MULTI bench



/Description

Multi Bench is a universal and multipurpose workbench, that can be modeled in order to provide full support for tiles in all different combinations (see pictures). The Multi Bench is supplied with a soft case which, thanks to a pair of wheels, makes transportation easy and safe.

/Equipped with

- 2 stands with foldable legs
- 8 aluminum profiles with fixing screw (max. 11 profiles)
- 1 soft case

/Compatible with

- Multi Bench
- Agile family
- Compact family
- Perfect Jolly
- Mini Multi Bench
- Lampo Cut

/Also buy with

- Agile family
- Compact family
- Perfect Jolly
- Mini Multi Bench
- Lampo Cut
- Easy Break
- Pulse
- Cargo

MULTI bench



QUICK LEG SYSTEM

Quick, fast and perfect system to open and close the legs.



OPTIONAL KIT SPACER

Kit of brackets that, attached to the workbench, support the slab by lifting it off the aluminum profiles to provide stable support | Art. SP11026



EASY TRANSPORT

Supplied with a soft case which, thanks to a pair of wheels, makes transportation easy and safe.



OPTIONAL B-LOCK

Micrometric adjustable tile locking System
Adjustable height and pressure (max 40 mm.)
For all the models | Art. 90262U

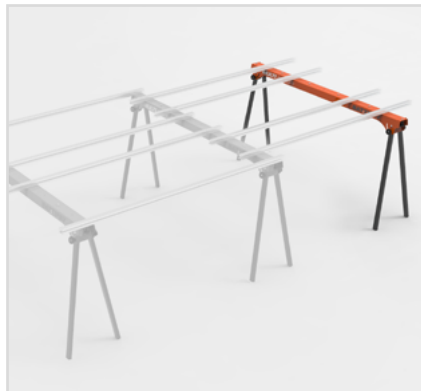

OPTIONAL EXTENSION



If you need more length, use extension kit to have a larger work bench | Art. 11202



COMPATIBLE WITH MACHINES

It is simple to link Multi Bench with some BattiPav electrical machines.

/Technical Info

ARTICLE	Technical info			Packaging info		
	MAXIMUM LOAD CAPACITY	MAX. LOAD CAPACITY WITH EXTENSION (art.11202)	ASSEMBLED PRODUCT DIMENSIONS			
MULTI BENCH (Art. 11201)	200 Kg	300 Kg	1500x1525x810 cm	1760x291x275 mm	14pz	720x1830x2070 mm

/Price list

ARTICLE	DESCRIPTION	KG	PRICE
11201	Multi Bench - 1500 mm - With 8 Aluminum Profiles And Bag	29,3	
> 11202	Extension Stand	8,5	
> 11203	Single Profile	1,5	
> 11204	Joint Set For All Multi Benches (2 Pcs.)	0,1	
> 11205	Joint For Prime/Supreme	0,6	
> SP11026	Kit 4 Spacer Caps	0,1	
> 90262U	B-Lock Universal Tile Locking System	1,2	

MINI MULTI bench



WATCH NOW ▶



/Description

Mini Multi Bench is a universal and multipurpose workbench, perfect to be used in small spaces. It is based on our Multi Bench but it is compact and can easily be transported anywhere.

We designed it to meet the needs of all of our customers, both those who deal with large formats and those who are specialized in precision work.

/Equipped with

- 2 stands with foldable legs
- 5 aluminum profiles with fixing screws (max. 7 profiles)
- 1 soft case

/Compatible with

- Mini Multi Bench
- Multi Bench
- Agile family
- Compact family
- Perfect Jolly
- Lampo Cut

/Also buy with

- Agile family
- Compact family
- Perfect Jolly
- Mini Multi Bench
- Lampo Cut
- Easy Break
- Pulse
- Cargo

LARGE FORMAT TILES TOOLS

MINI MULTI bench

LARGE FORMAT TOOLS

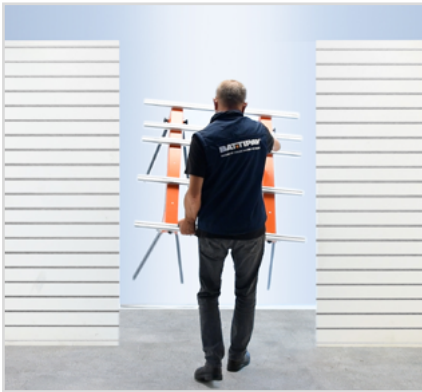

FAST MOVE

The bench can be easily moved even when fully assembled.



QUICK LEG SYSTEM

Quick, fast and perfect system to open and close the legs.



OPTIONAL KIT SPACER

Kit of brackets that, attached to the workbench, support the slab by lifting it off the aluminum profiles to provide stable support | Art. SP11026



EASY TRANSPORT

Supplied with a soft case which, thanks to a pair of wheels, makes transportation easy and safe.



JOINT SET



If you need more length, use the joint to have a larger work bench.



STRONG AND RELIABLE

Its dimensions further favor the structure, which is solid and of great stability.

/Technical Info

ARTICLE	Technical info			Packaging info		
	MAXIMUM LOAD CAPACITY	MAX. LOAD CAPACITY WITH EXTENSION (art.11202)	ASSEMBLED PRODUCT DIMENSIONS			
MINI MULTI BENCH (Art. 11206)	200 Kg	N.D.	1270x912x807 cm	1300x291x275 mm	10pz	1300x720x1530 mm

/PriceList

ARTICLE	DESCRIPTION	KG
11206	Mini Multi Bench - 912 mm - With 5 Aluminum Profiles And Bag	18,5
> 11202	Extension Stand	8,5
> 11203	Single Profile	1,5
> 11204	Joint Set Standard (2 Pcs.)	0,1
> 11205	Joint For Prime/Supreme	0,6
> SP11026	Kit 4 Spacer Caps	0,1
> 90262U	B-Lock Universal Tile Locking System	1,2

AGILE LIGHT_{plus}



WATCH NOW ▶



/Description

Agile Light Plus is a multipurpose frame for handling last generation slabs that are becoming now bigger and heavier. It is able to maintain its rigidity also under pressure avoiding dangerous bending movements that could lead to the break of the slab.

/Equipped with

- 2 telescopic bars with 2 handles
- 6 Suction Cups
- Kit Cross Bars | Art. 11003/1

/Compatible with

- Mini Multi Bench
- Multi Bench
- Agile family
- Perfect Jolly
- Lampo Cut

/Also buy with

- Agile family
- Compact family
- Perfect Jolly
- Mini Multi Bench
- Lampo Cut
- B-Lock
- Pulse
- Cargo

AGILE LIGHT_{plus}

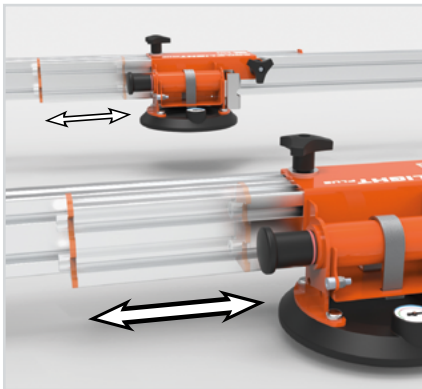

BARS

Advanced mechanism for telescopic bar.



FAST HANDLE

The knob has been designed to have a handy grip that guarantees to work easily even with the heaviest loads.

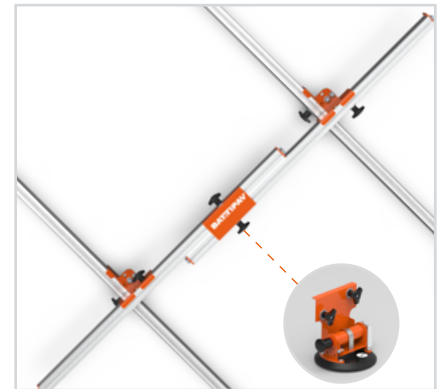

OPTIONAL SUCTION CUP FOR CROSS BARS

Add some extra grip with some Suction Cups in the Cross Bars | Art. 11004/1



OPTIONAL KIT CARRIAGE

Carriage for easy and safe handling, complete with wheels | Art. 11005/1

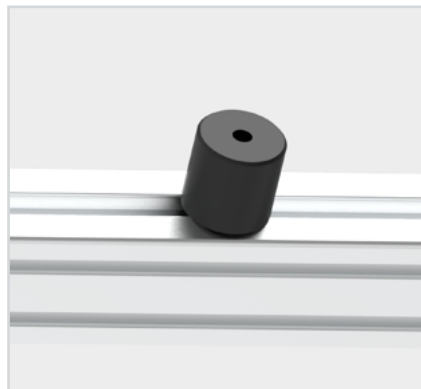

OPTIONAL KIT SPACER

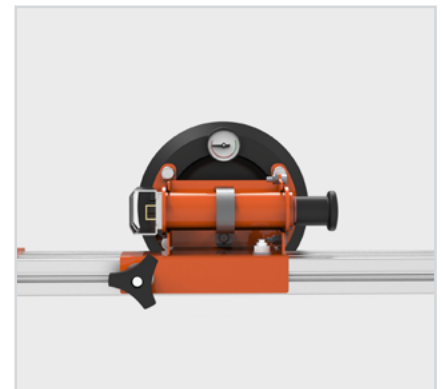

Kit of brackets that, attached to the workbench, support the slab by lifting it off the aluminum profiles to provide stable support | Art. SP11026



PROFESSIONAL SUCTION CUP

High quality professional Suction Cups with vacuum indicator. Resistant rubber with special design for perfect adherence on rough surfaces. Complete with support | Art. 11004/1

/Technical Info

ARTICLE	Technical info		Packaging info		
	MAX/ MIN BAR LENGTH	MAX/ MIN BAR WIDTH			
AGILE LIGHT PLUS (Art. 11006/1)	3300 mm - 1720 mm	1580 mm - 840 mm	1795x640x255 mm	8pz	650x1795x2060 mm

/PriceList

ARTICLE	DESCRIPTION	KG
11006/1	Agile Light Plus	37,5
> 11005/1	Kit Carriage Agile	8,5
> 11004/1	Suction Cup For Cross Bars	1,3
> SP11026	Kit 4 Spacer Caps	0,1

AGILE LIGHT



WATCH NOW ▶



/Description

Agile Light is an essential handling system for large format tiles, perfect for not heavy-duty tasks. It could be integrated with Kit Cross Bars (Art. 11003/1), and become Agile Light Plus.

/Equipped with

- 1 telescopic bar with 2 handles
- 3 Suction Cups

/Compatible with

- Mini Multi Bench
- Multi Bench
- Agile family
- Perfect Jolly
- Lampo Cut

/Also buy with

- Agile family
- Perfect Jolly
- Mini Multi Bench
- Lampo Cut
- Easy Break
- Pulse
- Cargo

AGILE LIGHT

LARGE FORMAT TOOLS

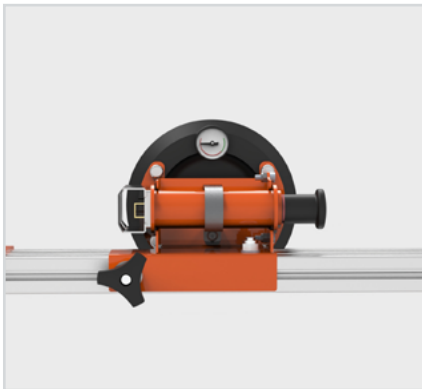

PROFESSIONAL SUCTION CUP

High quality professional Suction Cups with vacuum indicator. Resistant rubber with special design for perfect adherence on rough surfaces. Complete with support | Art. 11004/1



FAST HANDLE

The knob has been designed to have a handy grip that guarantees to work easily even with the heaviest loads.



MECHANISM

Ad hoc mechanism for telescopic bar.



ALUMINIUM STRUCTURE

The structure is made of aluminum to be more rigid.



OPTIONAL KIT CARRIAGE

Carriage for safe and easy movements, complete with wheels | Art. 11005/1

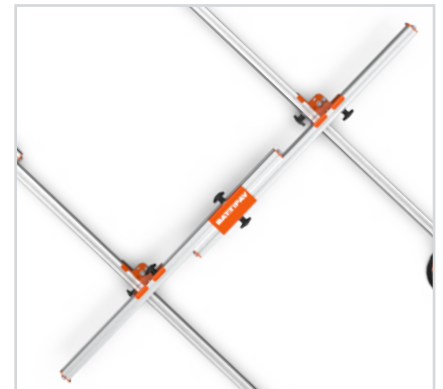

OPTIONAL KIT CROSSBARS

Is it possible to add the cross bars to make it become stronger | Art. 11003/1

/Technical Info

ARTICLE	Technical info	Packaging info		
	MAX/MIN BAR LENGTH			
AGILE LIGHT (Art. 11002/1)	3300 mm - 1720 mm	1830x320x120 mm	32pz	720x 1830x 2070 mm

/PriceList

ARTICLE	DESCRIPTION	KG
11002/1	Agile Light - 1 Bar With 3 Suction Cups	12,2
> 11003/1	Kit Cross Bars for Agile	5,0
> 11005/1	Kit Carriage Agile	8,5
> 11004/1	Suction Cup With Support For Agile	1,3

COMPACT LIGHT-PLUS



NEW
PRODUCT
2024

/Description

Compact Light Plus is a multipurpose frame for handling large format slabs. It is able to maintain its rigidity also under pressure avoiding dangerous bending movements that could lead to the break of the slab. This new system is even lighter than Agile Light Plus but it can carry up to 80Kg.

/Equipped with

- 2 telescopic bars with 2 handles
- 6 Suction Cups
- Kit Cross Bars | Art. 11003/1

/Compatible with

- Mini Multi Bench
- Multi Bench
- Compact family

/Also buy with

- Multi Bench
- Mini Multi Bench
- Lampo Cut
- Pulse
- Cargo

LARGE FORMAT TILES TOOLS

COMPACT LIGHT-PLUS

LARGE FORMAT TOOLS

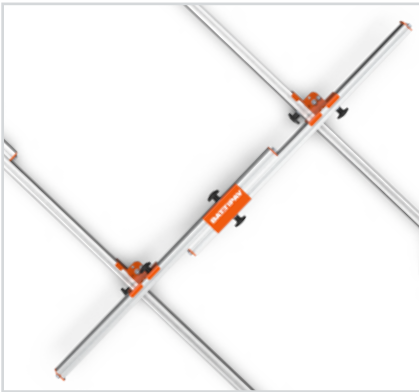

PROFILE BARS

The structure is made of aluminum to ensure rigidity. The section is 30x30mm, specifically designed for a perfect balance between large format tiles and high effective material resistance.



READY TO WORK

It is sold already assembled so it is possible to use it as soon as it is delivered.

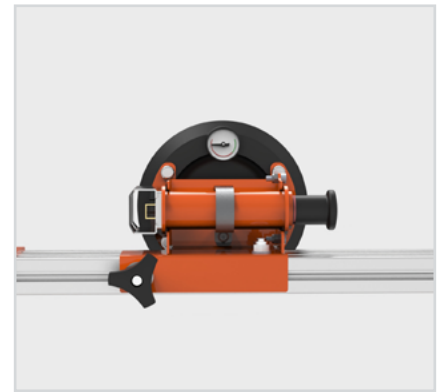

PROFESSIONAL SUCTION CUP

High quality professional Suction Cups with vacuum indicator. Resistant rubber with special design for perfect adherence on rough surfaces.



BARS

Advanced mechanism for telescopic bars.



FAST HANDLE



The knob has been designed to have a handy grip that guarantees to work easily even with the heaviest loads.



LIGHTER RESISTANT STRUCTURE

The lighter weight makes the work easier and as secure as usual.

/Technical Info

ARTICLE	Technical info		Packaging info		
	MAX/ MIN BAR LENGTH	MAX/ MIN CROSS BAR WIDTH			
COMPACT LIGHT PLUS (Art. 11007)	3300 mm - 2030 mm	1660 mm - 890 mm	1900x615x 205 mm	8pz	1950x720 x1790 mm

/PriceList

ARTICLE	DESCRIPTION	KG
11007	Compact Light Plus	23,5

COMPACT LIGHT



NEW
PRODUCT
2024

/Description

Compact Light is an essential handling system for large format tiles: light and efficient at the same time. This new system is even lighter than Agile Light.

/Equipped with

- 1 telescopic bar with 2 handles
- 3 Suction Cups

/Compatible with

- Mini Multi Bench
- Multi Bench
- Compact family

/Also buy with

- Multi Bench
- Mini Multi Bench
- Lampo Cut
- Pulse
- Cargo

LARGE FORMAT TILES TOOLS

COMPACT LIGHT

LARGE FORMAT TOOLS



ALUMINIUM STRUCTURE

The structure is made of aluminum to ensure rigidity. The section is 30x30mm, specifically designed for a perfect balance between large format tile and high effective material resistance.



HEAVY LOAD DUTY

It can carry heavy materials with its own weight of only 12kg.



PROFESSIONAL SUCTION CUP

High quality professional Suction Cups with vacuum indicator. Resistant rubber with special design for perfect adherence on rough surfaces.



TELESCOPIC BARS

Advanced mechanism for telescopic bars.



FAST HANDLE



The knob has been designed to have a handy grip that guarantees to work easily even with the heaviest loads.



LIGHTER RESISTANT STRUCTURE

The lighter weight makes the work easier and as secure as usual.

/Technical Info

ARTICLE	Technical info	Packaging info		
	MAX/ MIN BAR LENGTH			
COMPACT LIGHT (Art. 11008)	3300 mm - 2030 mm	1835x335x125 mm	32pz	720x 1830x 2070 mm

/PriceList

ARTICLE	DESCRIPTION	KG
11008	Compact Light	12,20

CARGO

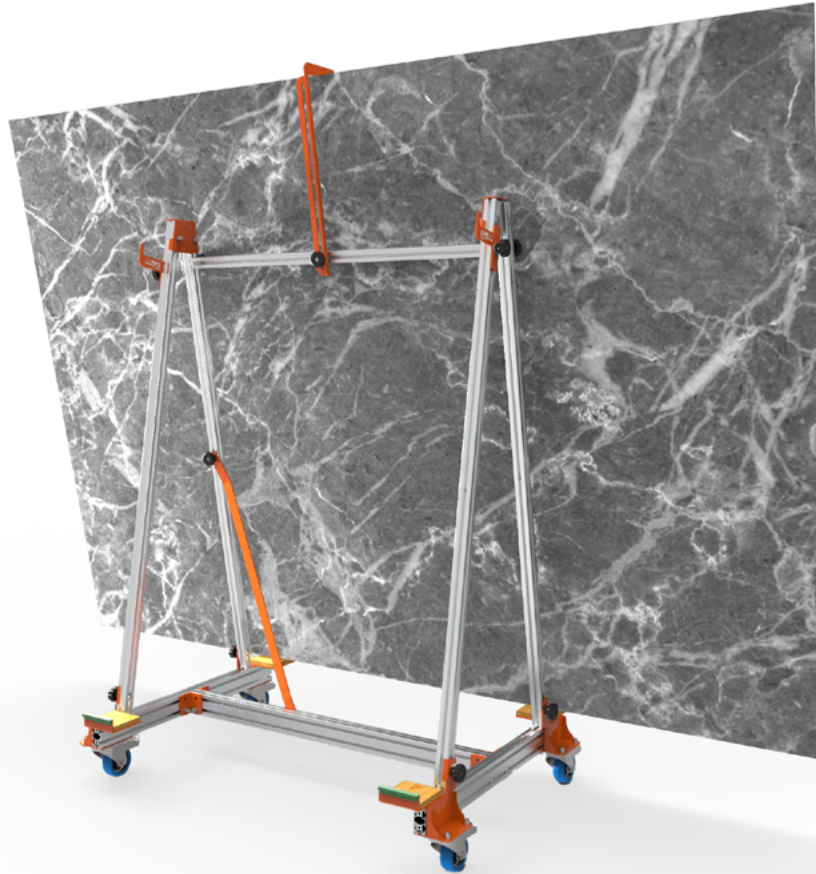

NEW
PRODUCT
2024

/Description

Cargo is a trolley for transporting and handling of large format slabs, facilitating their sliding also on uneven floors. It is equipped with a vibration-absorption system and it can be combined with Battipav large slab devices.

/Equipped with

- Vibration-absorption system
- Safety hook
- Wooden supports
- Pivoting wheels with brake

/Compatible with

- Mini Multi Bench
- Multi Bench
- Agile family
- Compact family
- Lampo Cut

/Also buy with

- Agile family
- Compact family
- Mini Multi Bench
- Multi Bench
- Lampo Cut
- Suction cup



FAST ASSEMBLY

The structure is in aluminium to get rigidity. Section is 30x30mm, specifically designed for a perfect balance between large format tile and high effective material resistance.

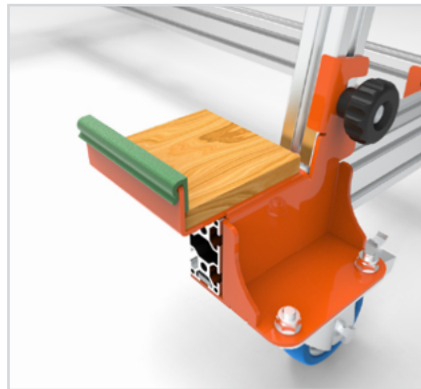

SUPPORT WITH VIBRATION REDUCTION

It has specific wooden supports to better cushion the vibrations caused by uneven surfaces.

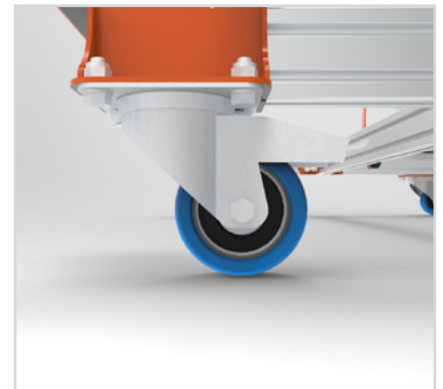

PIVOTING WHEELS

It is equipped with 4 swivel wheels with brakes, to allow easy movement of large format slabs.

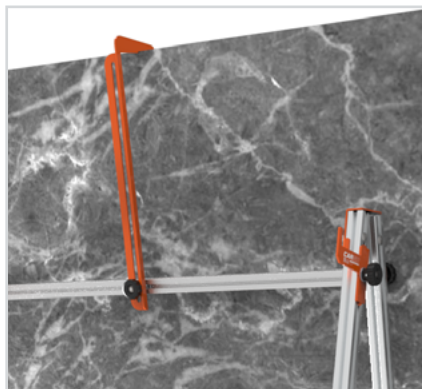

SAFETY HOOK

Cargo allows you to move one or more slabs using the safety hook to avoid accidental unhooking.

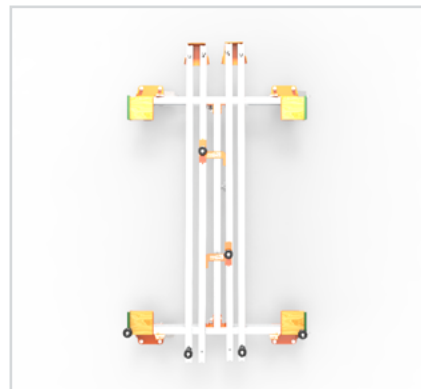

EASY TO TRANSPORT

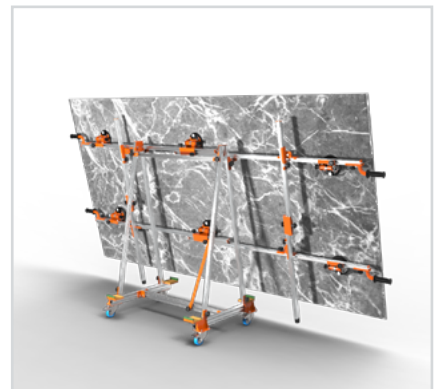

Cargo can be easily reduced for easy transportation.



COMPATIBLE WITH OTHER PRODUCTS

The design of Cargo allows it to be easily used in relation to other paving systems (Agile or Compact family).

/Technical Info

ARTICLE	Technical info		Packaging info		
	MAX SLAB HANDLING SIZE	MAX CARRY CAPACITY			
CARGO (Art. 11601)	1600x3200 mm	250 KG	1320x758x285 mm	6pz	1320x758x1860 mm

/PriceList

ARTICLE	DESCRIPTION	KG
11601	Cargo - Large Format Slabs Display	25

PERFECT jolly

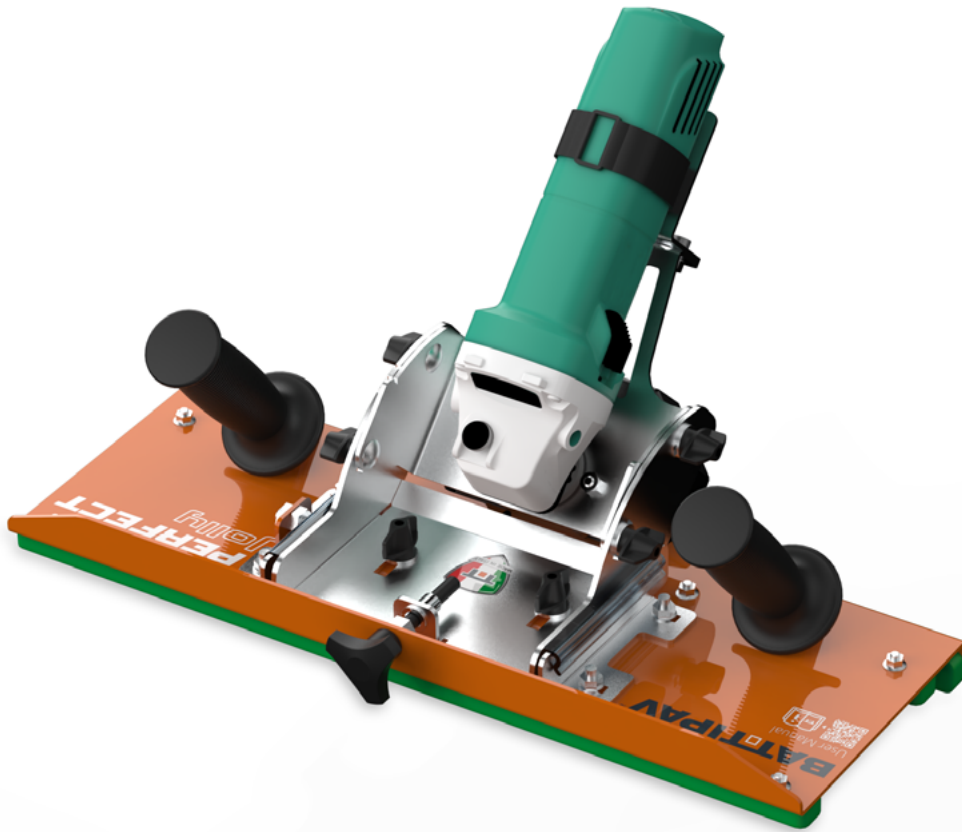

WATCH NOW ▶



/Description

Perfect Jolly is the tool that solves the dilemma of the Jolly cuts on the construction site. Fully adjustable both in depth and angle, it is composed of a rigid base that slides on the tile by means of polyethylene pads (does not include grinder).

/Equipped with

- Screw to remove and insert the disc

/Compatible with

- Mini Multi Bench
- Multi Bench
- Agile family
- Compact family
- Spacer Kit

/Also buy with

- Agile family
- Compact family
- Mini Multi Bench
- Multi Bench
- Lampo Cut
- Pulse

PERFECT jolly

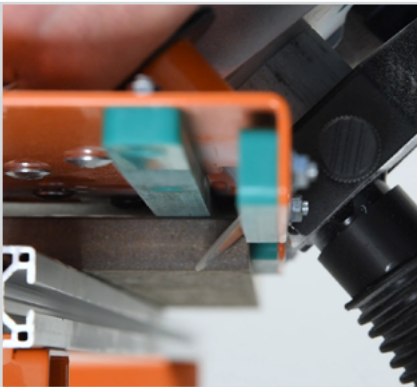

BEVEL DEPTH

Adjustable bevel depth, with maximum cutting height of 21 mm, disc cover with dust extraction.



OPTIONAL DISK

Only usable with Ø115 disks. Art. TNSB115D or TNSP115D



STRUCTURE

It has a strong structure, with polyethylene pads for a precise and fluid sliding. Equipped with practical and comfortable handles.



OPTIONAL SHAFT ATTACHMENT

The version sold in North America has a 5/8" - 11 arbor attachment.



INCLINATOR

Adjustable cut for inclinations from 40° to 50°.



EQUIPMENT

Equipped with an allen key to speed up the operation of replacing the diamond disc in the pin.

/Technical Info

ARTICLE	Technical info				Packaging info		
				SHAFT			
PERFECT JOLLY (Art. 11401)	∞	21 mm	Ø 115 mm	M14	530x340x255 mm	32pz	675x1060x2160 mm

/PriceList

ARTICLE	DESCRIPTION	KG
11401	Perfect Jolly Ø 115	5,0
> TNSB115D	Diamond Disk Ø115 Gres/Natural Stone Bestever, Dry	18,5

SUCTION CUP



/Description

Suction Cup is a very useful tool as it helps to easily handle big tiles and, consequently, to spare time improving the productivity of the operator. It has a comfortable metal handle, a monometer with indication of the current pressure (improved security), a button for fast release of pressure and a plastic box for transport. The W-shape of rubber makes it suitable to be used even with rough surfaces.

/Equipped with

- Resistant Light Case
- High quality professional suction cup with vacuum indicator

/Compatible with

- Mini Multi Bench
- Multi Bench
- Agile family
- Compact family
- Perfect Jolly
- Lampo Cut

/Also buy with

- Agile family
- Compact family
- Perfect Jolly
- Mini Multi Bench
- Multi Bench
- Lampo Cut
- Easy Break
- Pulse

SUCTION CUP

LARGE FORMAT TOOLS



VACUUM

High quality professional Suction Cups with vacuum indicator. Resistant rubber with special design for perfect adherence on rough surfaces.



CASE

Resistant ultra-light case.

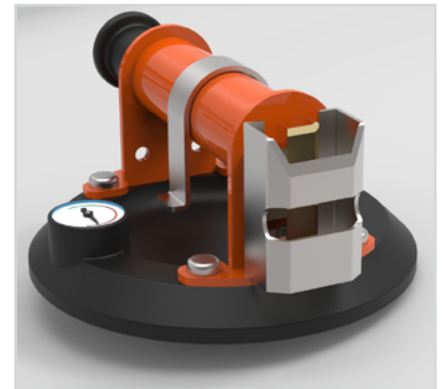

FAST PRESSURE RELEASE

By pushing the aluminium part, the vacuum system is released.



RUBBER

Resistant rubber with special design for perfect adherence on rough surfaces.

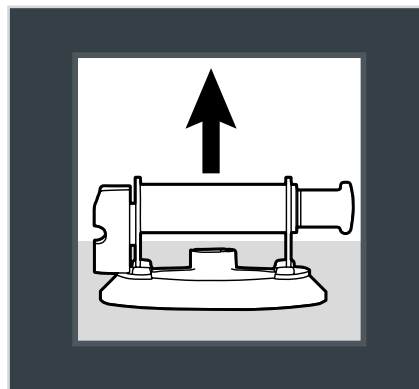

HORIZONTAL POSITION

Maximum lifting capacity 100Kg.

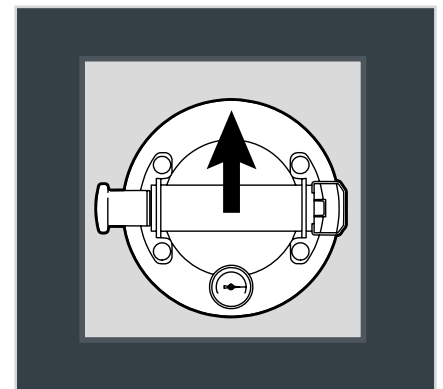

VERTICAL POSITION

Maximum sliding capacity 50kg.

/Technical Info

	Technical info	Packaging info
ARTICLE	SUCTION CUP DIAMETER	
SUCTION CUP (Art. 11047)	Ø 150 mm	150x180x85 mm

/PriceList

ARTICLE	DESCRIPTION	KG
11047	Suction Cup With Manometer And Plastic Case	1,5

PULSE



WATCH NOW ▶



/Description

Pulse is a professional battery-powered vibrator designed to work with large format tiles and slabs. It expels the air guaranteeing perfect adherence.

/Equipped with

- Resistant Light Chase
- Heavy Duty Battery
- Universal Charger
- Angular Beating plate

/Compatible with

- Mini Multi Bench
- Multi Bench
- Agile family
- Compact family

/Also buy with

- Agile family
- Compact family
- Mini Multi Bench
- Multi Bench
- Lampo Cut



PICK AND PLACE

Pulse is equipped with: Suction Cup and practical lever for a very fast "Pick & Place". Maximum 25 kg per tile.



INTENSITY LEVEL

Press the white rubberized button on the handle. The vibration intensity levels are regulated by a turning wheel.



BEATING PLATE

Specific beating plate with angular shape for easier access to corners. It was inspired by the old vibrator model MiniVibro produced by Battipav in 70s.



BATTERY

High capacity long lasting battery.



SUCTION CUP

Perfect adherence to every kind of material.



CASE

Hard shell for maximum comfort during transport.

/Technical Info

ARTICLE	Technical info						Packaging info		
	VOLTAGE	CURRENT INTENSITY	POWER AVAILABLE	RPM (vibrations)	SUCTION CUP Ø	PLATE DIMENSION			
PULSE (Art. 11501/1)	18V DC	2AH	36WH	MIN 500 MAX 12.000	Ø 130 mm thickness 7MM	200X300 X8 mm	430x265 x180 mm	60pz	840x1200 x1500 mm

/PriceList

ARTICLE	DESCRIPTION	KG
11501/1	Pulse - Suction Cup Vibrator V.1 With Extension Plate	3,4
> 11502	Extension Plate	0,1
> 11503/1	Battery For Pulse V.1	0,4
> 11520/48	Charger For Pulse With Adaptors	0,0



**MANUAL TILE CUTTERS
RANGE 2024**

MANUAL TILE CUTTER

BATTIPAV

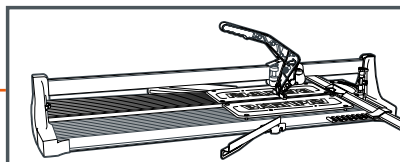

SINTESI

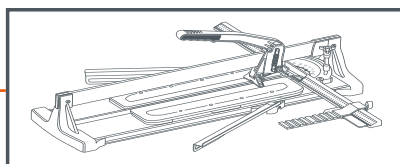

ProfiEVO

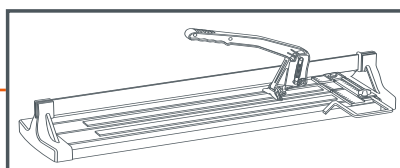

LEGGERA

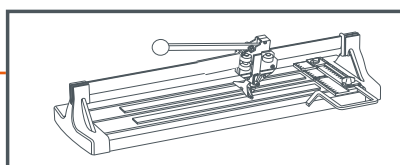

SUPER PROEVO

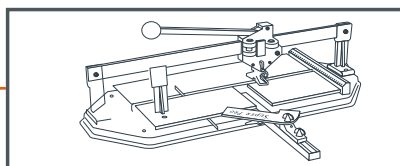

SUPER PRO

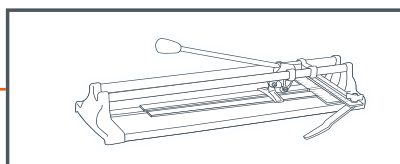

BASIC^{plus}

SINTESI



WATCH NOW ▶



/Description

Sintesi is the top of our range of manual tile cutters. It encompasses all the end-user's needs we have heard on construction sites, at trade fairs or talking to our importers. Our goal is to always offer you the best. **Extra spare wheel included.**

/Advantages

- Quick start system
- Breaking foot with magnet
- Solid side extensions
- Aluminium monoblock goniometric square
- Extra spare wheel

/Characteristics

- Working table in shaped and cushioned steel with cutting line in stainless steel
- QR with explanation on how to set up the Indicator for the perfect bar height
- To "Push Cut"

/Range

- 93 cm
- 133 cm
- 163 cm
- 183 cm

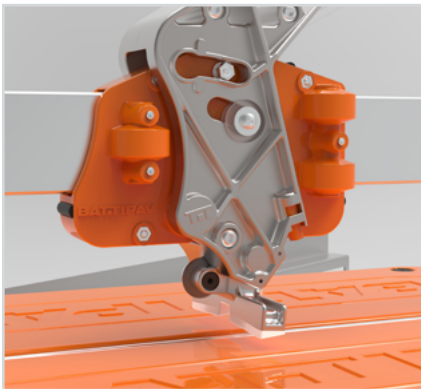

ALUMINIUM MAGNETIC FOOT

It is created with a white rubber protection to avoid scratches. The magnet allows to make the incision with a single move. Lift the handle and create an incision: the foot is then ready to accurately break the tile.

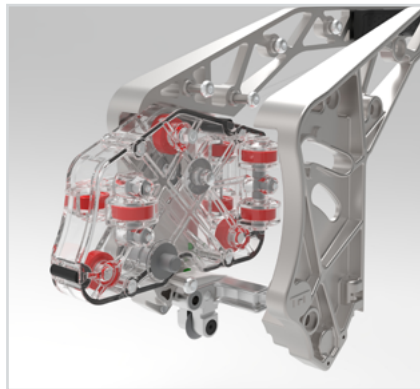

CARRIAGE

The carriage in aluminum is equipped with 9 ball bearings for extremely smooth and precise movements.

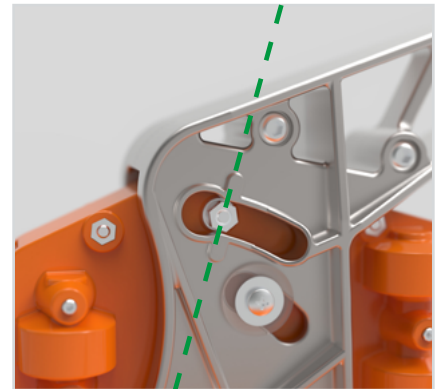

SETUP ALIGNMENT

It's easy to find the correct setup for your carriage, just by aligning it in a few seconds to the indicator for a perfect adjustment.

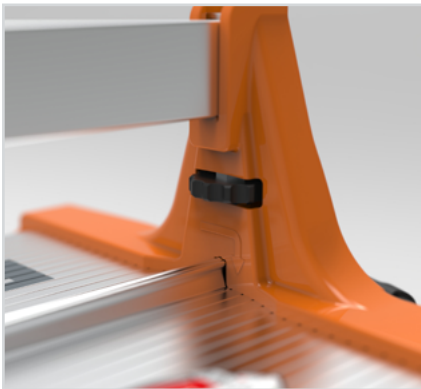

BAR HEIGHT ADJUSTMENT

The bar height is adjustable to the specific tile thickness so to have the best possible performance. Moreover, it is 15mm thick for more precision during the long cuts.

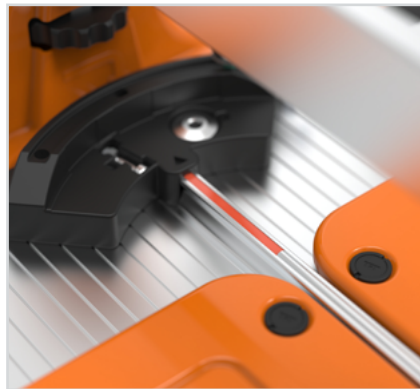

BREAKING LINE

It is made of stainless steel for maximum durability with a rubber amortization insert at the breaking point for extra protection of the tile edge.

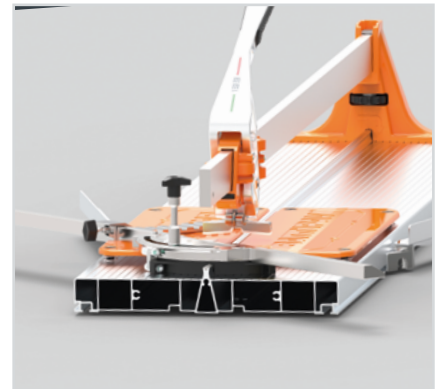

STRUCTURE

It has a strong and large body made in aluminum drawplate to ensure rigidity and lightness at the same time (profile width 35cm).

/Technical Info

ARTICLE	Technical info				Packaging info		
SINTESI 93 (Art. 40093)	930 mm	655x655 mm	4-21 mm	Ø22x6,1x4,7 mm	454x1396x340 mm	12pz	920x1410x1170 mm
SINTESI 133 (Art. 40133)	1330 mm	940x940 mm	4-21 mm	Ø22x6,1x4,7 mm	454x1796x340 mm	12pz	920x1810x1170 mm
SINTESI 163 (Art. 40163)	1630 mm	1152x1152 mm	4-21 mm	Ø22x6,1x4,7 mm	454x2096x340 mm	12pz	920x1410x1170 mm
SINTESI 183 (Art. 40183)	1830 mm	1290x1290 mm	4-21 mm	Ø22x6,1x4,7 mm	454x2296x340 mm	12pz	920x2310x1170 mm

MANUAL TILE CUTTER

SINTESI



SET-UP

Indicator for perfect bar height set up



ADDITIONAL SPARE WHEEL

Extra spare wheel included.

GONIOMETRIC SQUARE

Aluminium monoblock with high readability of the measurements, locking device for fast diagonal cut setting and lateral fence for cuts in series.

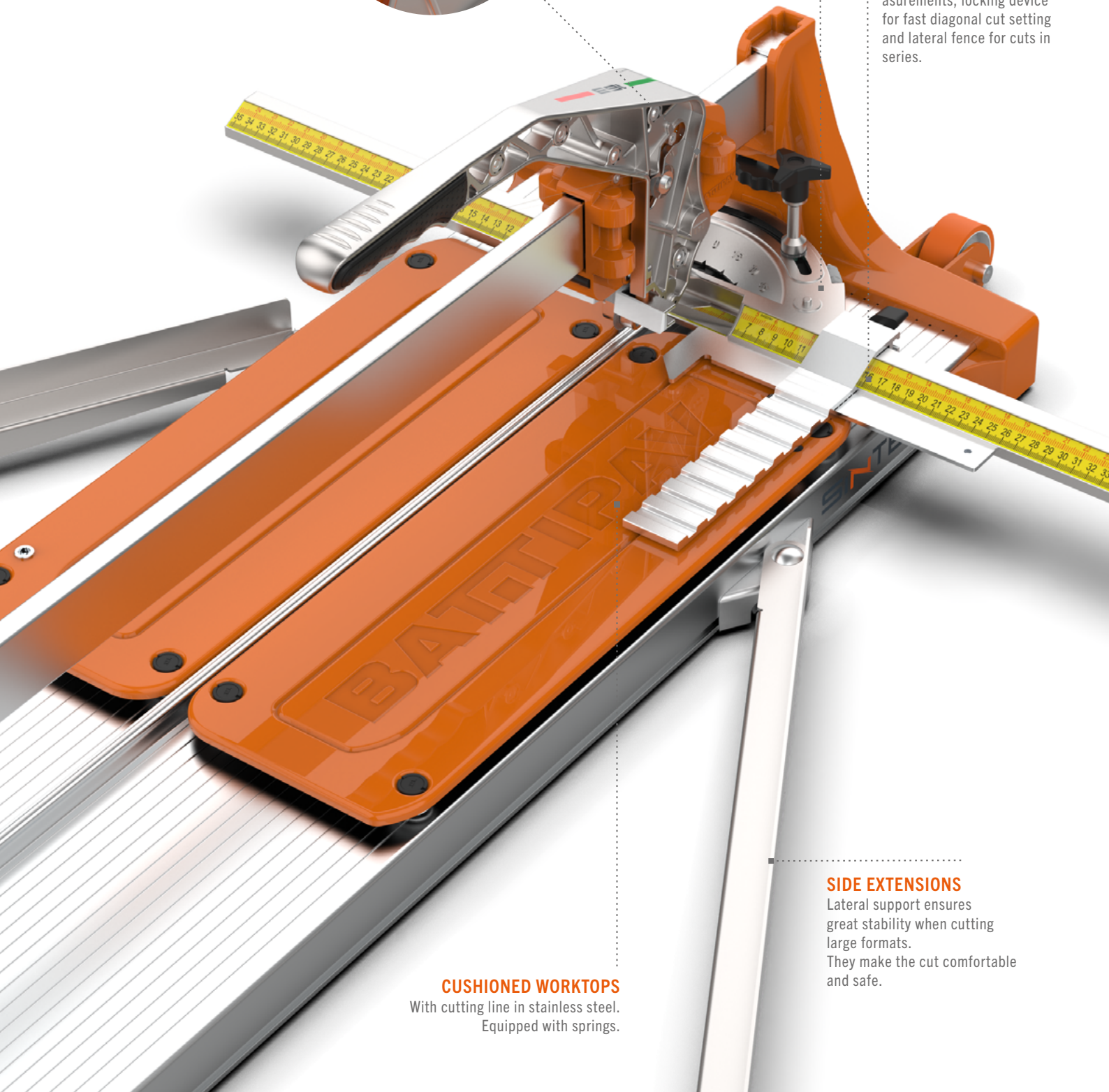





CUSHIONED WORKTOPS

With cutting line in stainless steel.
Equipped with springs.

SIDE EXTENSIONS

Lateral support ensures great stability when cutting large formats.
They make the cut comfortable and safe.

/Fittings

	ART.	DESCRIPTION		
	492	KIT SPARE WHEEL Ø22X6,1X4,7 MM	6	0,2
	K26	REINFORCED DISPLAY FOR MANUAL TILE CUTTERS	1	20,0
	K27	DISPLAY FOR ONE MANUAL TILE CUTTER	1	10,5

MANUAL TILE CUTTER

/Price list

ARTICLE	DESCRIPTION	KG
40093	Sintesi 93 **	24,0
40133	Sintesi 133 ***	28,0
40163	Sintesi 163 ***	33,0
40183	Sintesi 183 ****	36,0

** With one side extension / ** With two side extensions / *** With four side extensions / **** With six side extensions*

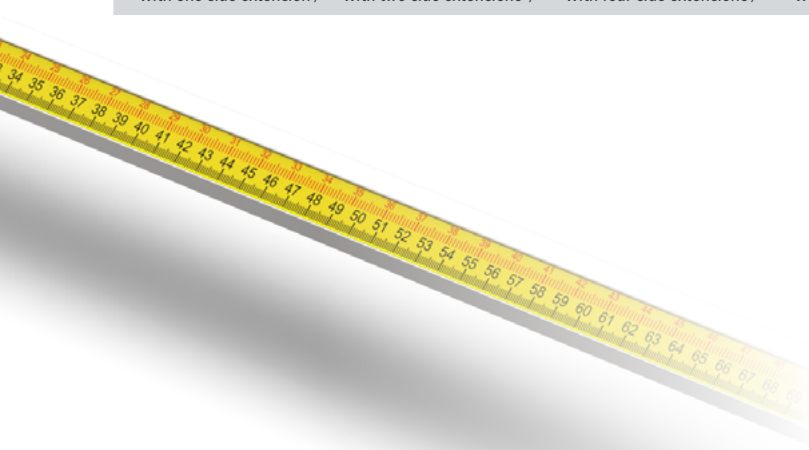

ProfiEVO



WATCH NOW ▶



/Description

Profi Evo Super professional "TO PUSH" tile cutter for diagonal and straight cuts on single-fired ceramic and porcelain stoneware tiles. It is equipped with an aluminum carriage with two adjustable ball bearings for perfect sliding and maximum precision. The goniometric square has a direct reading of the measurement for straight and diagonal cuts.

/Advantages

- Aluminium structure, for stability and lightness
- Quick start system: the springs makes the handle always ready
- Breaking foot with magnet
- Solid side extensions
- Aluminium monoblock goniometric square

/Characteristics

- Carriage with 2 adjustable ball-bearings
- To "Push Cut"
- Extra spare wheel

/Range

- 45 cm
- 63 cm
- 88 cm
- 103 cm
- 133 cm
- 163 cm

ProfiEVO

MANUAL TILE CUTTER

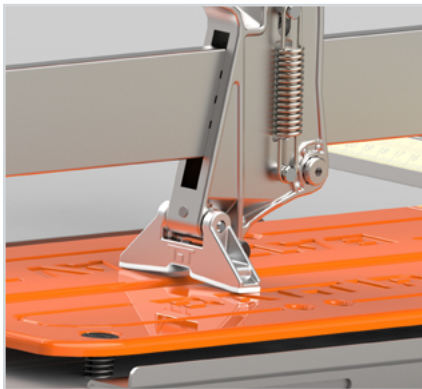

ALUMINIUM MAGNETIC FOOT

The aluminum breaking foot is equipped with an anti-scratch rubber. Scoring and breaking are faster and more comfortable: all in one operation.



CARRIAGE

The carriage is equipped with two adjustable ball-bearings for perfect sliding.

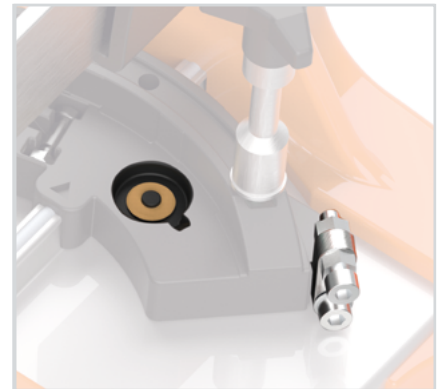

LOCKING DEVICE AND SPARE WHEEL

It allows you to immediately find "0°" as a reference system, making diagonal cuts more practical. An extra spare wheel is also included.

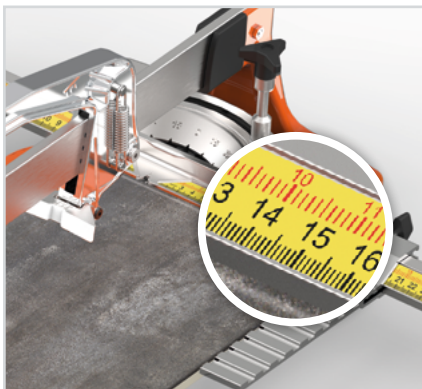

QUICK READING

The designed goniometric square allows a perfect reading of the measurement for both straight cut (black lower scale) and diagonal cut (red upper scale).



GONIOMETRIC SQUARE

Innovative design, stronger and more precise. The bar is inclined for a perfect reading of the measurement.

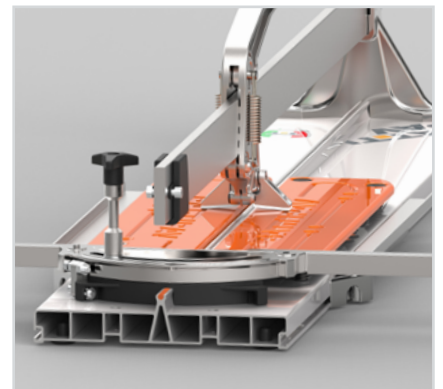

STRUCTURE

It has a strong and large body made in aluminum drawplate to ensure rigidity and lightness at the same time.

/Technical Info

ARTICLE	Technical info				Packaging info		
PROFI EVO 45 (Art. 6401EV)	450 mm	320x320 mm	5-15 mm	Ø15x6x1,5 mm	816x295x280 mm	28 pz	82x120x208 cm
PROFI EVO 63 (Art. 6601EV)	630 mm	440x440 mm	5-15 mm	Ø15x6x1,5 mm	1000x295x280 mm	28 pz	100x120x208 cm
PROFI EVO 88 (Art. 6850EV)	880 mm	620x620 mm	5-15 mm	Ø15x6x1,5 mm	1250x295x280 mm	21 pz	88x125x208 cm
PROFI EVO 103 (Art. 61000EV)	1030 mm	720x720 mm	5-15 mm	Ø15x6x1,5 mm	1404x295x280 mm	21 pz	88x140x208 cm
PROFI EVO 133 (Art. 61300EV)	1330 mm	940x940 mm	5-15 mm	Ø15x6x1,5 mm	1704x295x280 mm	14 pz	72x175x208 cm
PROFI EVO 163 (Art. 61600EV)	1630 mm	1150x1150 mm	5-15 mm	Ø15x6x1,5 mm	1996x295x280 mm	14 pz	72x199x208 cm

MANUAL TILE CUTTER

ProfiEVO

COMFORTABLE HANDLE

With SOFT GRIP for a better work.

BREAKING FOOT

The breaking foot is in aluminium with anti-scratch rubber and provided with a magnet.

QUICK START SYSTEM

The carriage is provided with springs that make the handle always ready to cut.

SPARE WHEEL

Extra spare wheel included.

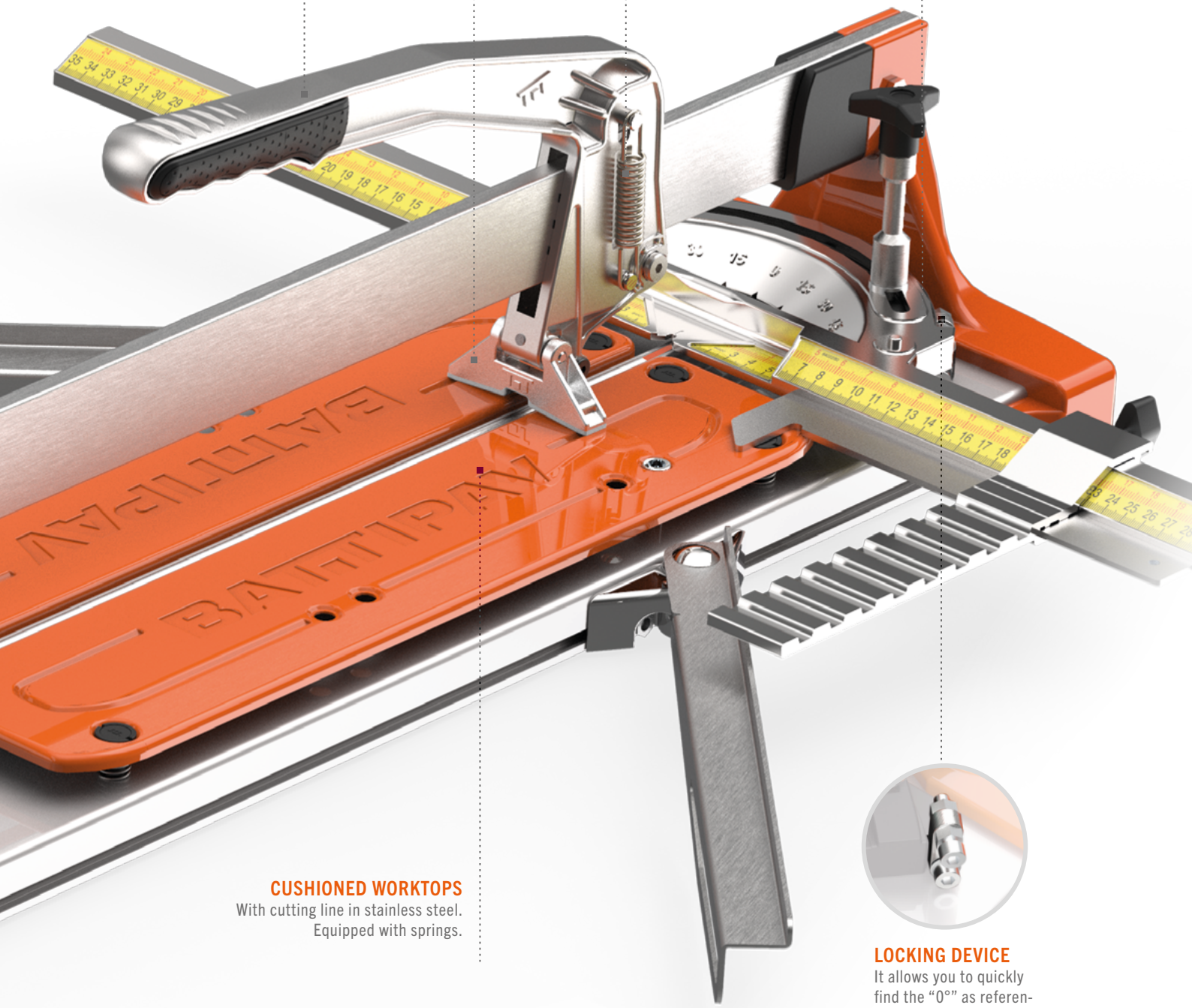

CUSHIONED WORKTOPS

With cutting line in stainless steel. Equipped with springs.





LOCKING DEVICE

It allows you to quickly find the "0°" as reference system making more practical diagonal cuts.

ProfiEVO

/Fittings

	ART.	DESCRIPTION		
	2009	Kit spare wheel Ø22x6,1x4,7 mm	6	0,1
	K25	DISPLAY FOR MANUAL TILE CUTTERS	1	20,0
	K27	DISPLAY FOR ONE MANUAL TILE CUTTER	1	10,5
	68510I	SOFT CASE L. 1220MM for PROFI EVO 88, 63	1	3,5
	613010I	SOFT CASE L. 1670MM for PROFI EVO 133, 103	1	5,0
	68510IS	SOFT CASE 1220 MM - 5 PCS for PROFI EVO 88, 63	1	21,0
	613010IS	SOFT CASE 1670 MM - 5 PCS for PROFI EVO 133, 103	1	26,0

MANUAL TILE CUTTER

/Price list

ARTICLE	DESCRIPTION	KG
6401EV	Profi Evo 45 *	7,8
6601EV	Profi Evo 63 *	9,1
6850EV	Profi Evo 88 **	13,0
61000EV	Profi Evo 103 **	14,5
61300EV	Profi Evo 133 ***	17,5
61600EV	Profi Evo 163 ***	20,5

* With one side extension / ** With two side extensions / *** With four side extensions

PACKAGING EXAMPLE



LEGGERA



WATCH NOW ▶



/Description

Leggera is a professional tile cutter "TO PUSH" for diagonal and straight cuts on single-double fired ceramic and porcelain stoneware tiles. The aluminum carriage is equipped with two adjustable ball bearings for perfect sliding and maximum precision. It's super light and gives maximum portability.

/Advantages

- Aluminium structure which gives stability and lightness
- Solid side extensions
- Magnetic breaking foot

/Characteristics

- Carriage with 2 adjustable ball-bearings
- To "Push Cut"

/Range

- 49 cm
- 67 cm
- 92 cm
- 137 cm

LEGGERA



DIAGONAL CUTS

Square ruler with direct reading for diagonal cuts.

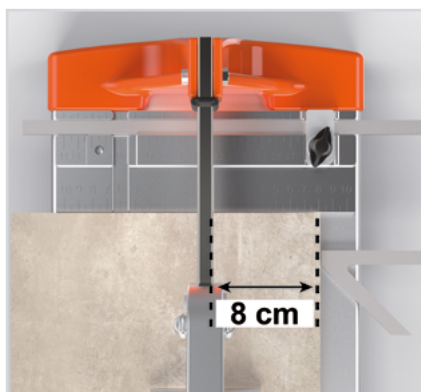

STRAIGHT CUTS

Square ruler with direct reading for straight cuts.

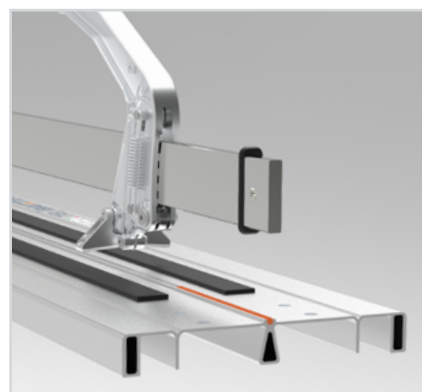

STRUCTURE

It has a strong and large body made in aluminum drawplate to ensure rigidity and lightness at the same time.



QUICK START SYSTEM

The carriage is provided with springs that make the handle always ready to cut.

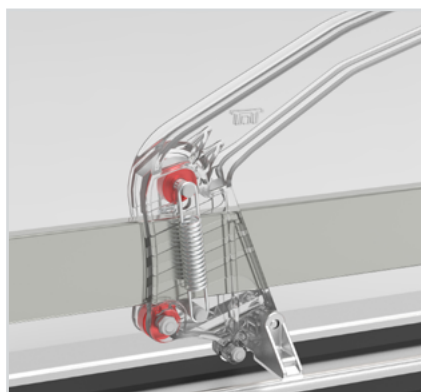

CARRIAGE

The carriage is equipped with two adjustable ball-bearings for perfect sliding.



ALUMINIUM MAGNETIC FOOT

The aluminum breaking foot is equipped with an anti-scratch rubber. Scoring and breaking are faster and more comfortable: all in one operation.

/Technical Info

ARTICLE	Technical info				Packaging info		
LEGGERA 49 (Art. 6401E)	490 mm	345x345 mm	4-15 mm	Ø15x6x1,5 mm	830x295x280 mm	28 pz	82x120x208 cm
LEGGERA 67 (Art. 6601E)	670 mm	470x470 mm	4-15 mm	Ø15x6x1,5 mm	1004x295x280 mm	28 pz	100x120x208 cm
LEGGERA 92 (Art. 6900E)	920 mm	650x650 mm	4-15 mm	Ø15x6x1,5 mm	1260x295x280 mm	21 pz	90x120x206 cm
LEGGERA 137 (Art. 61300E)	1370 mm	965x965 mm	4-15 mm	Ø15x6x1,5 mm	1704x295x280 mm	14 pz	72x175x208 cm

MANUAL TILE CUTTER

LEGGERA

MAGNETIC BREAKING FOOT

The breaking foot is in aluminium with anti-scratch rubber and is equipped with a magnet.

QUICK START SYSTEM

The carriage is provided with springs that make the handle always ready to cut.

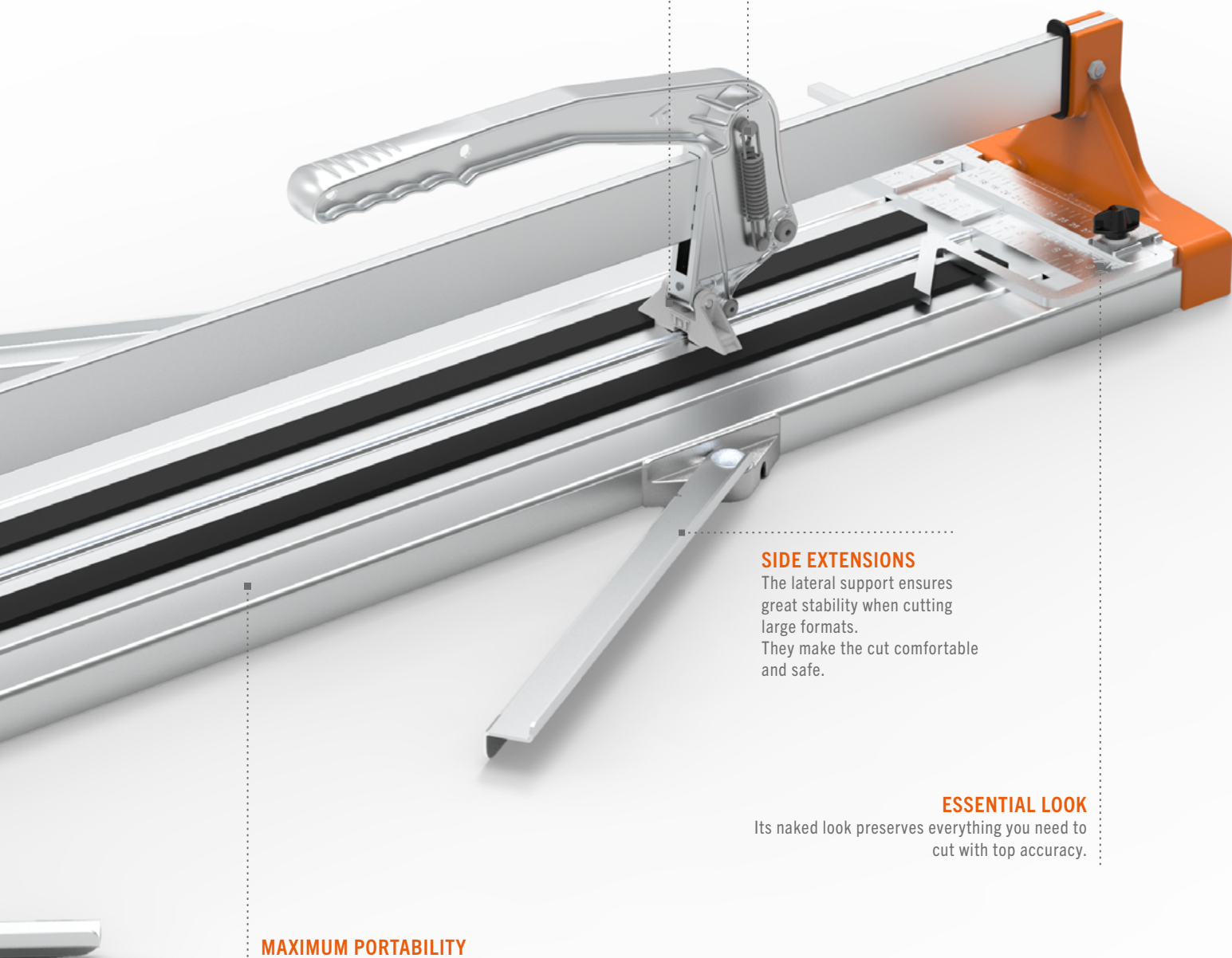

SIDE EXTENSIONS

The lateral support ensures great stability when cutting large formats. They make the cut comfortable and safe.

ESSENTIAL LOOK











Its naked look preserves everything you need to cut with top accuracy.

MAXIMUM PORTABILITY

Patented BATTIPAV aluminum extrusion for a super light weight.

LEGGERA

/Fittings

	ART.	DESCRIPTION		
	2009	KIT SPARE WHEEL Ø15X6X1,5 mm	6	0,2
	SP64025E	KIT LEFT & RIGHT EXTENSION FOR LEGGERA-SUPER PRO EVO	1	0,7
	K25	DISPLAY FOR MANUAL TILE CUTTERS	1	20,0
	K27	DISPLAY FOR ONE MANUAL TILE CUTTER	1	10,5
	68510I	SOFT CASE L. 1220MM for LEGGERA 49 - 67	1	3,5
	613010I	SOFT CASE L. 1670 MM for LEGGERA 92 - 137	1	5,0
	68510IS	SOFT CASE 1220 MM - 5 PCS for LEGGERA 49 - 67	1	21,0
	613010IS	SOFT CASE L. 1670 MM - 5 PCS for LEGGERA 92 - 137	1	28,5

MANUAL TILE CUTTER

/Price list

ARTICLE	DESCRIPTION	KG
6401E	Leggera 49	5,6
6601E	Leggera 67 *	6,6
6900E	Leggera 92 **	9,6
61300E	Leggera 137 ***	12,3

* With one side extension / ** With two side extensions / *** With four side extensions

SUPER PRO EVO

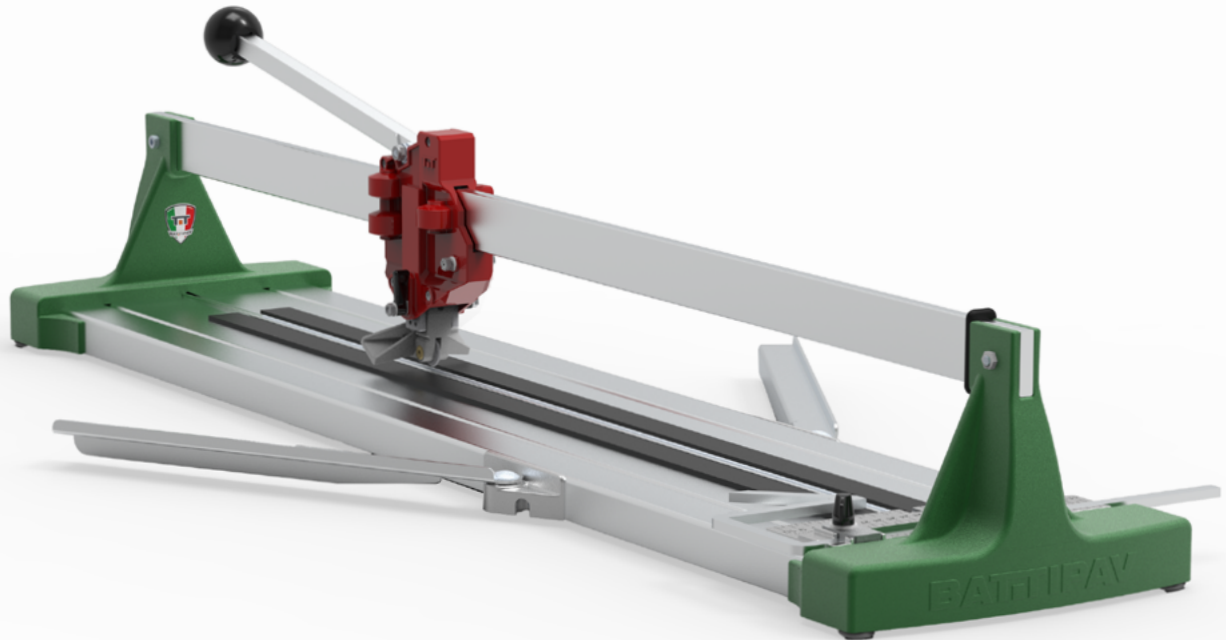

WATCH NOW ▶



/Description

Super Pro Evo is a super professional tile cutter for diagonal and straight cuts on single-double fired ceramic and gres. The carriage is equipped with nine ball-bearings, four of which are adjustable, to ensure a perfect sliding. The diagonal fence is included.

/Advantages

- Aluminium structure, which gives stability and lightness
- Solid side extensions

/Characteristics

- Carriage with 9 ball-bearings 4 of which are adjustable
- To "Push Cut"

/Range

- 65 cm
- 90 cm
- 125 cm

SUPER PRO EVO

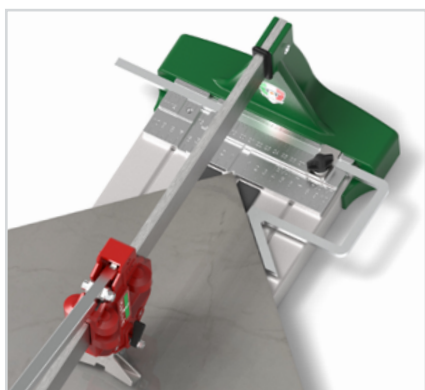

DIAGONAL CUTS

Square ruler with direct reading for diagonal cuts.



STRAIGHT CUTS

Square ruler with direct reading for straight cuts.

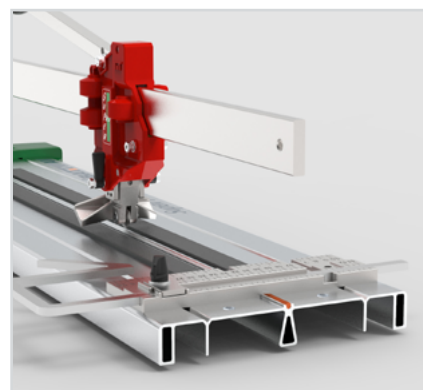

STRUCTURE

It has a strong and large body made in aluminum drawplate to ensure rigidity and lightness at the same time.

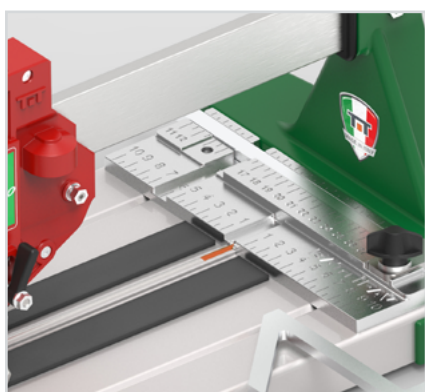

TILE SUPPORT

It is made in aluminum with a very visible millimeter scale.

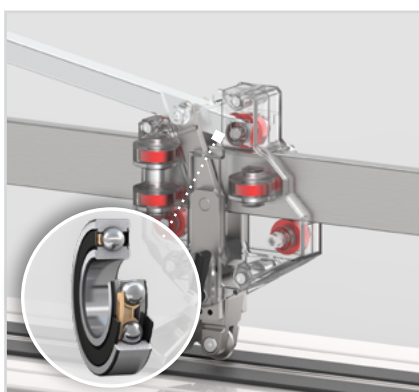

CARRIAGE

The carriage is equipped with 9 ball-bearings, 4 of which are adjustable to assure a perfect sliding and top precision.

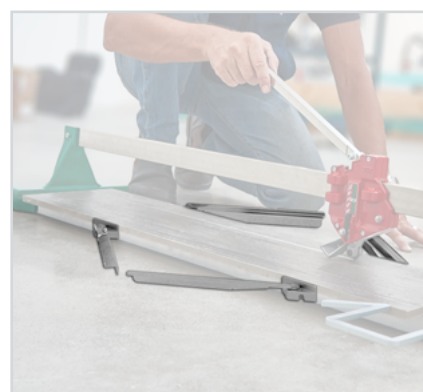

EXTENSION SUPPORT

Lateral support ensures great stability when cutting large formats. They make the cut comfortable and safe.

/Technical Info

ARTICLE	Technical info				Packaging info		
SUPER PRO EVO 65 (Art. 3565)	650 mm	460x460 mm	4-18 mm	Ø22x6,1x4,7 mm	1000x300x210 mm	40 pz	100x120x225 cm
SUPER PRO EVO 90 (Art. 3590)	900 mm	636x636 mm	4-18 mm	Ø22x6,1x4,7 mm	1250x300x210 mm	30 pz	90x125x225 cm
SUPER PRO EVO 125 (Art. 35125)	1250 mm	884x884 mm	4-18 mm	Ø22x6,1x4,7 mm	1600x300x210 mm	20 pz	72x175x225 cm

MANUAL TILE CUTTER

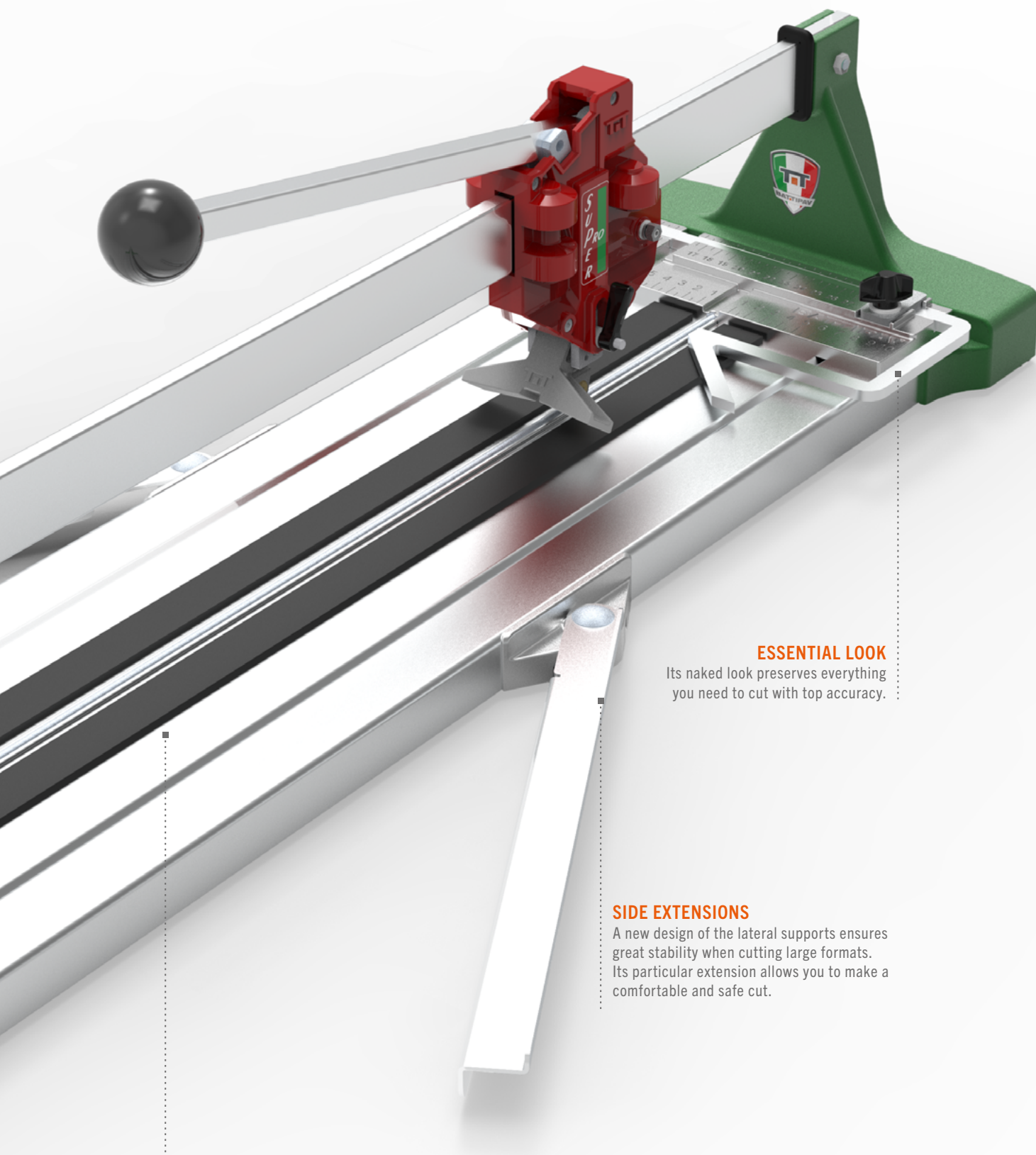

ESSENTIAL LOOK

Its naked look preserves everything you need to cut with top accuracy.

SIDE EXTENSIONS











A new design of the lateral supports ensures great stability when cutting large formats. Its particular extension allows you to make a comfortable and safe cut.

MAXIMUM PORTABILITY

Patented BATTIPAV aluminum extrusion for a super light weight.

SUPER PRO EVO

/Fittings

	ART.	DESCRIPTION		
	492	KIT SPARE WHEEL Ø22X6,1X4,7 MM	6	0,2
	SP64025E	KIT LEFT & RIGHT EXTENSION FOR LEGGERA-SUPER PRO EVO	1	0,7
	K25	DISPLAY FOR MANUAL TILE CUTTERS	1	20,0
	K27	DISPLAY FOR ONE MANUAL TILE CUTTER	1	10,5
	68510I	SOFT CASE L. 1220 MM FOR SUPER PRO EVO 125	1	3,5
	613010I	SOFT CASE L. 1670MM FOR SUPER PRO EVO 90, 65	1	5,0
	68510IS	SOFT CASE 1220 MM - 5 PCS FOR SUPER PRO EVO 90, 65	1	21,0
	613010IS	SOFT CASE 1670 MM - 5 PCS FOR SUPER PRO EVO 125	1	26,0

MANUAL TILE CUTTER

/Price list

ARTICLE	DESCRIPTION	KG
3565	Super Pro Evo 65 *	8,0
3590	Super Pro Evo 90 **	9,5
35125	Super Pro Evo 125 ***	11,5

* With one side extension / ** With two side extensions / *** With four side extensions

SUPER PRO

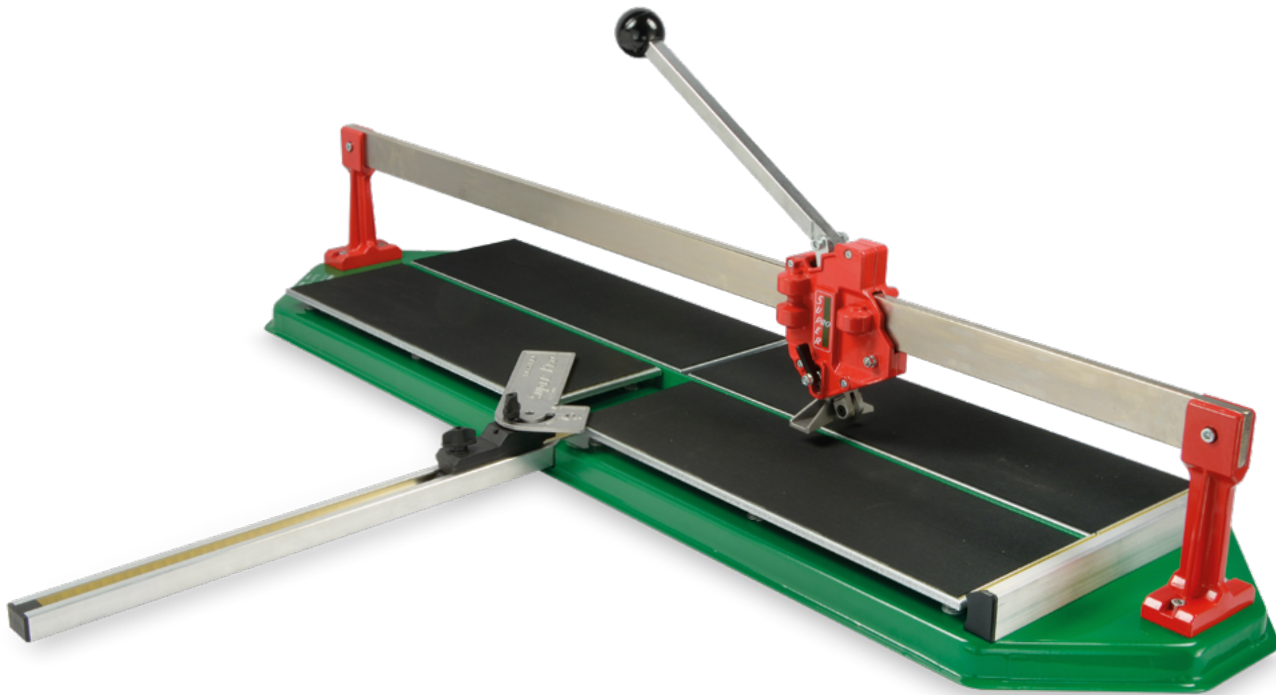

WATCH NOW ▶



/Description

Super Pro is a professional tile cutter for diagonal and straight cuts on single-double fired ceramic and gres. The carriage is equipped with nine ball-bearings, four of which are adjustable, to ensure a perfect sliding and top precision. The diagonal fence is included, and the working table is planned for a perfect cut.

/Advantages

- The working table is equipped with springs to make the tiles' break easier

/Characteristics

- Carriage with 9 ball-bearings
- To "Push Cut"

/Range

- 60 cm
- 75 cm
- 90 cm



MADE IN ITALY

A seal of quality is engraved on each product to identify origin and authenticity.



TILE CUTTING

You have the possibility to break the tile in every point.

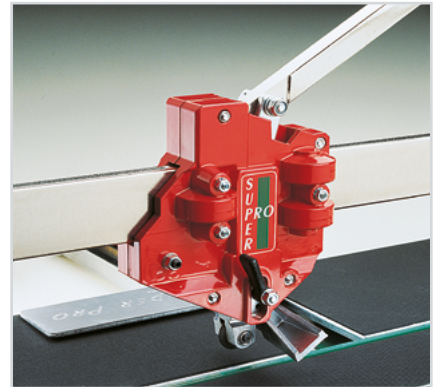

CUTTING WHEEL

Max. cutting thickness from 5 to 19 mm. and big size cutting wheel Ø 22 mm.



STORAGE

It was designed to reduce overall dimensions during transport and above all the storage space.

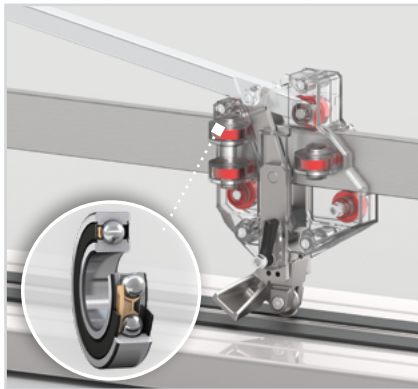

CARRIAGE

The carriage is equipped with nine ball-bearings, four of which are adjustable, to ensure a perfect sliding and top precision.



WORKING TABLE

Each working table is equipped with springs to make the tiles' break easier.

/Technical Info

ARTICLE	Technical info				Packaging info		
SUPER PRO 600 (Art. 3060)	600 mm	420x420 mm	5-19 mm	Ø22x6,1x4,7 mm	860x340x160 mm	22 pz	73x87x204 cm
SUPER PRO 750 (Art. 3075)	750 mm	530x530 mm	5-19 mm	Ø22x6,1x4,7 mm	1010x340x160 mm	22 pz	73x103x204 cm
SUPER PRO 900 (Art. 3090)	900 mm	635x635 mm	5-19 mm	Ø22x6,1x4,7 mm	1160x340x160 mm	22 pz	73x117x204 cm

MANUAL TILE CUTTER

SUPER PRO

DIAGONAL FENCE

Diagonal fence with direct reading of the measurement on its supporting rod.

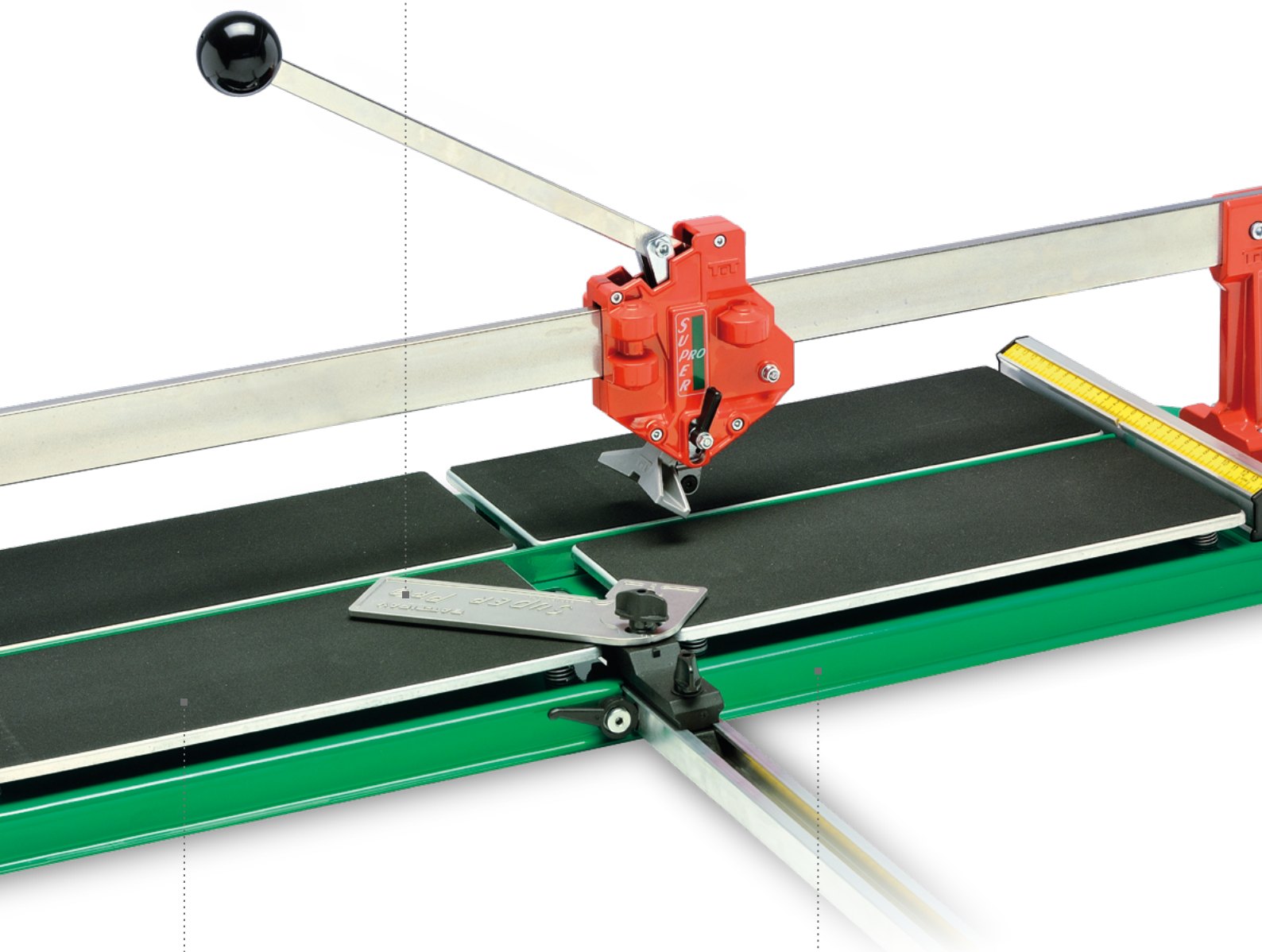

STRUCTURE







Very strong sheet body.

WORKING TABLE

Equipped with springs to make the tiles' break easier.

SUPER PRO

/Fittings

	ART.	DESCRIPTION		
	492	KIT SPARE WHEEL Ø22X6,1X4,7 MM	6	0,2
	K25	DISPLAY FOR MANUAL TILE CUTTERS	1	20,0
	68510I	SOFT CASE L. 1220 MM FOR SUPER PRO 900 - 750 - 600	1	3,5
	68510IS	SOFT CASE 1220 MM - 5 PCS FOR SUPER PRO 900 - 750 - 600	1	21,0

MANUAL TILE CUTTER

/Price list

ARTICLE	DESCRIPTION	KG
3060	Super Pro 600	13,5
3075	Super Pro 750	16,0
3090	Super Pro 900	18,5

BASIC^{plus}



WATCH NOW ▶

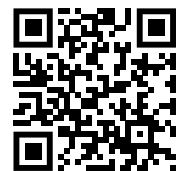

/Description

Basic Plus is a manual tile cutter for diagonal and straight cuts on single-double fired ceramic and gres. The diagonal fence is included. It is simple and light, with a nice design and innovative technical solutions.

/Advantages

- IXEF parts for extremely low friction during cut
- Diagonal fences

/Characteristics

- Carriage with 2 adjustable ball-bearings
- Oval bars
- To "Push Cut"

/Range

- 40 cm
- 50 cm
- 60 cm

BASIC^{plus}

MANUAL TILE CUTTER



DIAGONAL FENCE

The diagonal fence has a graduated scale in cm and inch.



CUT

Cutting to push with possibility to break the tile in every point.

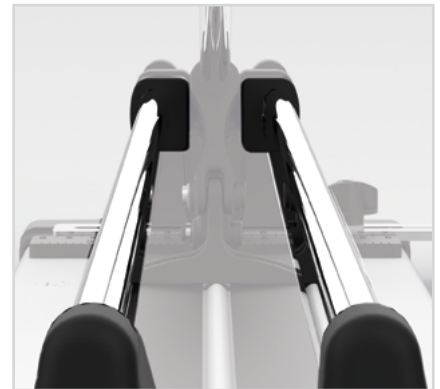

OVAL BARS

Sliding carriage on oval chromium plated bars.

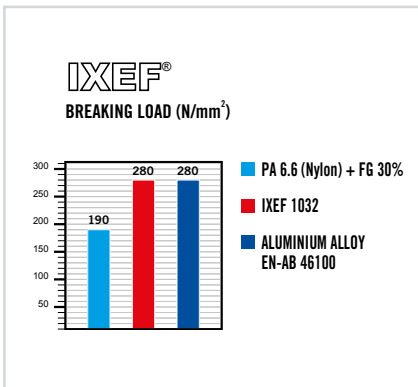

IXEF PARTS

5.000.000 cycles guaranteed without consumption.

NO LUBRICATION: the combination of IXEF with CHROME assures no friction at all.

NO MAINTENANCE: chromed bars are very resistant.

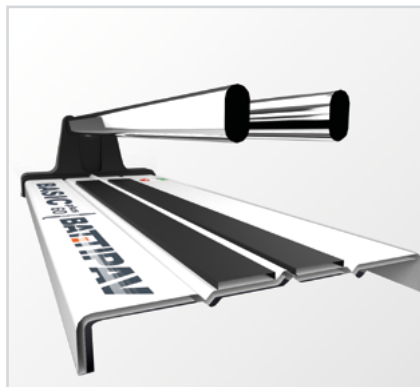

STRUCTURE

The base is shaped steel for high rigidity.

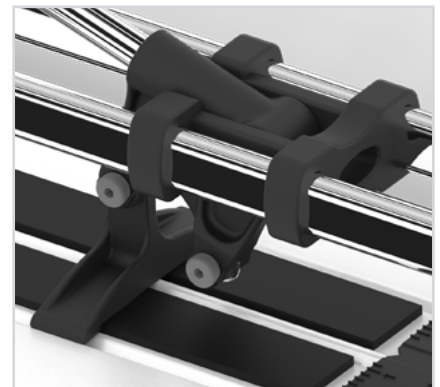

BREAKING SYSTEM

You have the possibility to break the tile in every point thanks to a new system of angulation between the wheel and the breaking foot.

/Technical Info

ARTICLE	Technical info				Packaging info		
BASIC PLUS 40 (Art. 2040)	400 mm	280x280 mm	4-12 mm	Ø15x6x1,5 mm	635x170x100 mm	90 pz	80x120x183 cm
BASIC PLUS 50 (Art. 2050)	500 mm	350x350 mm	4-12 mm	Ø15x6x1,5 mm	735x170x100 mm	90 pz	80x120x183 cm
BASIC PLUS 60 (Art. 2060)	600 mm	420x420 mm	4-12 mm	Ø15x6x1,5 mm	835x170x100 mm	90 pz	85x120x183 cm

MANUAL TILE CUTTER

BASIC^{plus}

BREAKING FOOT

Big size breaking foot for cutting the tile easier.
Cutting wheel Ø 15 mm.

BREAKING SYSTEM

Possibility to break the tile in every point thanks to a system of angulation between the wheel and the breaking foot.

STRUCTURE

The base is shaped steel for high rigidity.



DIAGONAL FENCE





Diagonal fence adjustable from 45° to 90°.

OVAL BARS

Sliding carriage on oval chromium plated bars.

BASIC^{plus}

/Fittings

	ART.	DESCRIPTION		
	2009	KIT SPARE WHEEL Ø15X6X1,5 mm	6	0,2
	K25	DISPLAY FOR MANUAL TILE CUTTERS	1	20,0

/Price list

ARTICLE	DESCRIPTION	KG
2040	Basic Plus 40	3,6
2050	Basic Plus 50	4,2
2060	Basic Plus 60	4,6



ELETTRIC MACHINES
RANGE 2024

BATTIPAV



PRIME 700



ELITE 80



PRIME



**EXTRA
SUPERLUNGA**



CLASSplus



VIP



EXPERT



EGO+PLUS



SUPREME



DYNAMIC



CLASS



Mixer



**Mini
Mix**



MIXIT



MASTER LINDA



**LINDA
VELOCE**

PRIME



WATCH NOW ▶







/Description

Prime 700 is the right bridge saw for cutting stones. New design with vanguard technical innovation, it is strong and precise, and suitable for cutting brick blocks, natural stones, proton, concrete blocks. It cuts by moving forward manually the motor group. This saw is designed to work with diamond disk Ø700mm. Laser for specific model.

/Characteristics

- Amperometric protection
- Sliding cutting head
- Kit wheels
- Water recycling pump type P3
- 45° jolly cut
- Stacking capability for storage
- Disk Ø700 not included
- Cutting progress system with hand wheel

/Trademarks

-  TT-Power
-  FastLeg
-  Spray System
-  Wdec
-  AxT

/Range

- PRIME 700S

PRIME 700

/Features



CUT
Cutting position for straight cuts.

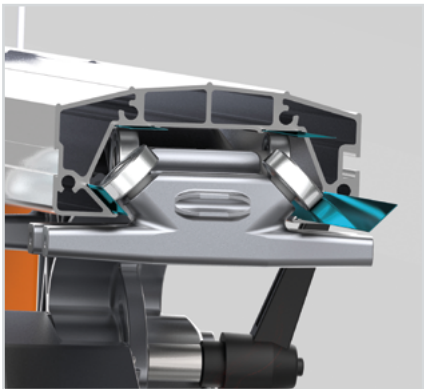

RAIL
The rail is equipped with interchangeable STAINLESS STEEL track for a perfect sliding of the motor group carriage.

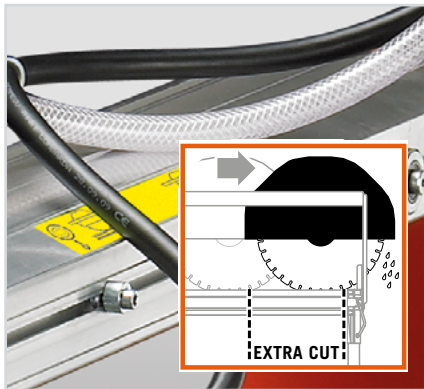

EXTRA CUT
Adjusting the end-run-carriage, it increases the cutting length.

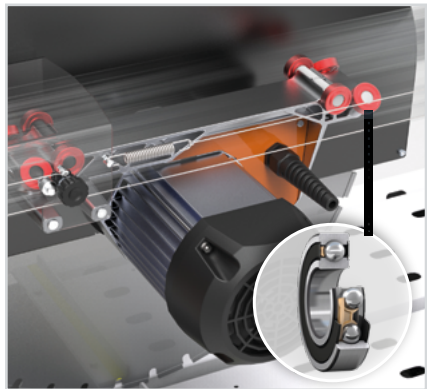

CARRIAGE
The carriage motor group slides with 8 ball-bearings on an interchangeable stainless steel track.



CUTTING PROGRESS SYSTEM
The cutting progress system with handwheel adjusts the movement of the cutting head forward or backward.



STORAGE
It was designed to reduce overall dimensions during transport and above all the storage space.

/Technical Info











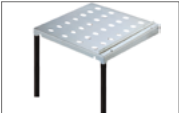

ARTICLE	Technical info										Packaging info	
PRIME 700S (Art. 90701)	5,5Hp / 4Kw, 8A	10-16 A	1400 / 1700	700 mm / 25,4 mm	615 mm	90701 -> 795 mm 90700 -> 970 mm	435 x 435 mm	275 mm	180 mm	855 x 625 mm	72x225 x 106 cm	72x225 x 176 cm (2 pcs)

/Fittings

ART.	DESCRIPTION		
90262U	B-LOCK TILE LOCKING SYSTEM FOR MATERIAL THICKNESS UP TO 40 MM	1	1,1
90102R	KIT WHEELS FOR ELITE/PRIME/SUPREME/EXPERT	1	4,9

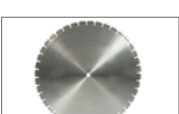
ELECTRIC MACHINES

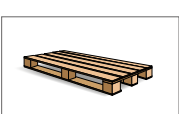
PRIME ⁷⁰⁰

	ART.	DESCRIPTION		
	90176R	2 SWIVEL WHEELS KIT	1	6,6
	90241	EXTENSION SIDE BENCH FOR PRIME/SUPREME/DYNAMIC	1	8,5
	90258C	EXTENSION SIDE TABLE WITH ROLLERS 600X800 MM	1	16,4
	90167/85U	SIDE TILE SUPPORT PRIME/SUPREME 85	1	3,6
	90167/15	LONG SLOT FOR SIDE TILE SUPPORT	1	1,7
	SP90159/T380	CEE SOCKET 400V + CABLE 3MT.	1	0,7
	90180	LIFTING BELT	1	0,9
	P3	WATER PUMP TYPE P3	6	8,5
	897	DIAMOND DISK Ø700 LASER UNIVERSAL, WET - HOLE 25,4	1	10,5
	70088U	UNIVERSAL FRONT HANDLE	1	0,5
	00012	PALLET 72X225 CM	1	20,0
	11201	MULTI BENCH	1	29,34
	11206	MINI MULTI BENCH	1	18,5

PRIME 700

/Price list

ARTICLE	DESCRIPTION	PHASE	KG
90701	Prime 700S *	3F	118,0
90700	Prime 700 **	3F	113,0
* With Laser And Wheels / ** With Laser		3F = 400V. 50/60Hz. (5,5Hp/4Kw)	

BRIDGE

The rail is an extrusion of aluminium with high resistance to the torsional stress. It's equipped with steel ball bearings running on interchangeable stainless steel tracks. Absolute cutting precision.

CUTTING PROGRESS SYSTEM

The cutting progress system with handwheel adjusts the movement of the cutting head forward or backward.



STRUCTURE

The structure is made of aluminium to ensure rigidity and lightness at the same time.

EXPERT



WATCH NOW ▶



/Description





Expert range is the ideal saw for the building sector. Innovative design with high tech solutions, very precise, compact, light and strong. It's suitable for cutting bricks, poroton blocks, marble blocks and all the different kind of materials for the building sector. It cuts by pushing the sliding working table.

These saws are designed to work with diamond disk Ø700-600-500-400.

/Characteristics

- Amperometric protection
- Sliding/Adjustable cutting head
- Kit wheels
- Water recycling pump
- Disks not included

/Trademarks

-  TT-Power
-  FastLeg
-  Spray System
-  Wdec
-  AxT

/Range

- Expert 700
- Expert 600S
- Expert 500S
- Expert 400S

/Features



ELECTRIC MACHINES

EXPERT



STRAIGHT CUTS

Cutting position with sliding carriage. (Expert 9700)



CUTTING DEPTH

It can cut at a max height of 34 cm with only 2 runs. (Expert 9700)



CUTTING BLADE ADJUSTMENT

Adjustment system of the cutting height with an hand wheel and relevant locking lever. (Expert 9700)

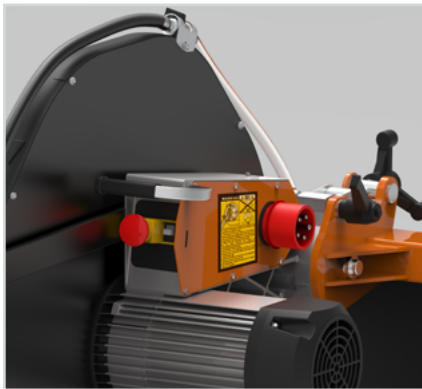

CONTROL BOARD

- Mushroom-head push button
- Overheat protection
- Plug with 5 pins (three-phase) for maximum security



STRUCTURE

The structure is made of aluminium to ensure rigidity and lightness at the same time. It has four handles for the carriage and movement.



STORAGE

It was designed to reduce overall dimensions during transport and above all the storage space.

/Technical Info

ARTICLE	Technical info									Packaging info	
EXPERT 700 (Art. 9700)	5,5Hp / 4Kw, 8A	10-16 A	1400 / 1700	700 mm / 25,4 mm	550 mm	389x389 mm	270 mm	340 mm	515 x 520 cm	72x160 x 108 cm	72x160 x 180 cm
				650 mm / 25,4 mm	580 mm	410x410 mm	240 mm				
EXPERT 600S (Art. 9601)	5,5Hp/4Kw, 8A	10-16 A	1400/1700	600 mm / 25,4 mm	750 mm	412 x 412 mm	220 mm	285 mm	442 x 520 mm	80x120 x 103 cm	80x120 x 180 cm
EXPERT 500S (Art. 9501)	5,5Hp/4Kw, 8A	10-16 A	1400 / 1700	500 mm / 25,4 mm	750 mm	412x412 mm	170 mm	235 mm	442 x 520 mm	80x120 x 103 cm	80x120 x 180 cm
EXPERT 400S (Art. 9401)	3,8Hp / 2,8Kw, 12A	16 A	2800	400 mm / 25,4 mm	570 mm	395 x 395 mm	135 mm	155 mm	442 x 520 mm	80x120 x 97 cm	80x120 x 227 cm (3pcs)







DO YOU WANT MORE INFO? CHECK THE BATTIPAV WEBSITE AT THIS LINK:
www.battipav.com or write us at sales@battipav.com

EXPERT

/Fittings

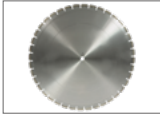
	ART.	DESCRIPTION		
	96109 94109	LASER INSTRUMENT FOR EXPERT 500/600 LASER INSTRUMENT FOR EXPERT 400	1	0,9 0,3
	90102R	KIT WHEELS	1	5,0
	90176R	2 SWIVEL WHEELS KIT	1	7,0
	SP90159/T380 SP90159/T230	CEE SOCKET 400V + CABLE 3 MT. CEE SOCKET 230V. 3 PHASE + CABLE 3MT.	1	0,7 0,8
	80036	45° ANGLE CUT COMPLETE	1	2,8
	90180	LIFTING BELT	1	0,9
	SP90340	TABLE LOCK FOR EXPERT LINE	1	0,2
	P3 P2	WATER PUMP TYPE P3 (FOR MODELS 700 - 600 - 500) WATER PUMP TYPE P2	6 12	8,5 13,6
	SP90159	CEE SOCKET 230V + CABLE 3MT. + SHUKO PLUG FOR EXPERT 400	1	0,6
	UNS400W	DIAMOND DISK Ø400 LASER UNIVERSAL, WET	1	2,7
	UNS500W	DIAMOND DISK Ø500 LASER UNIVERSAL, WET	1	4,1
	UNS600W	DIAMOND DISK Ø600 LASER UNIVERSAL, WET	1	6,3
	898	DIAMOND DISK Ø650 LASER UNIVERSAL , WET - HOLE 25,4	1	9,7

ART.	DESCRIPTION		
	897 DIAMOND DISK Ø700 LASER UNIVERSAL, WET - HOLE 25,4	1	10,5
	00010 PALLET 72X160 CM	1	15,0

/Price list

ARTICLE	DESCRIPTION	PHASE	KG
9700	Expert 700 ***		100,5
9700/M	Expert 700 ***		100,5
9621	Expert 600s XL *		86,0
9620/M	Expert 600 XL *		86,0
9601	Expert 600S *		86,5
9600	Expert 600		81,0
9601/M	Expert *		86,5
9600/M	Expert 600		81,0
9501	Expert 500S *		85,0
9500	Expert 500		79,5
9501/M	Expert 500S *		85,0
9500/M	Expert 500		79,5
9401	Expert 400S *		78,5
* With Laser And Wheels / ** With Laser / ***With Wheels		 = 230V. 50/60Hz. (4,5Hp/3,5Kw)	 = 400V. 50/60Hz. (5,5Hp/4Kw)

ELECTRIC MACHINES

ELITE 80



WATCH NOW ▶



/Description





Elite 80 is a masonry saw ideal for the building sector.

It has an ergonomic design with vanguard technical innovations, compact and strong. It's suitable for cutting bricks, stones, concrete-blocks, granite, marble and natural stones. It cuts by pushing the sliding working table or plunging the cutting head. It is designed to work with disks Ø350 mm.

/Caratteristiche

- Amperometric protection
- Overheat protection with manual reset
- Adjustable cutting head
- Sliding working table
- Water recycling pump type P2
- Disk Ø 350 not included
- 45° jolly cut
- Stacking capability for storage

/Trademarks

-  TT-Power
-  FastLeg
-  Spray System
-  Wdec
-  AxT

/Range

- Elite 80S

/Features



ELECTRIC MACHINES

ELITE 80



SPRAY SYSTEM

Patented system that improves the lubrication of diamond discs and ensures higher cutting performance and longer-lasting blades.

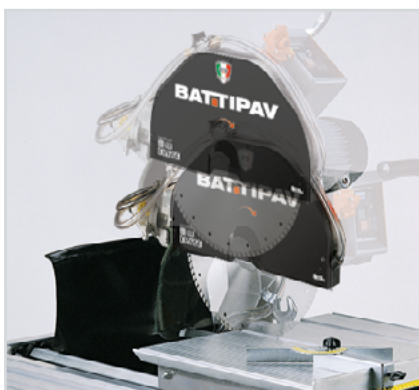

TILTING CUTTING HEAD

Tilting cutting head for a greater rapidity and precision in the execution of particular cuts. It can be locked at the wished height.

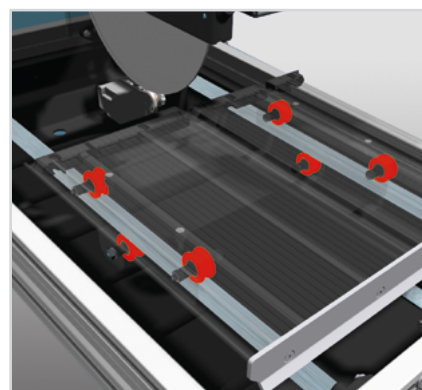

CARRIAGE

Working table with sliding carriage equipped with 6 adjustable nylon wheels and 12 ball-bearings to get a perfect stability and sliding.

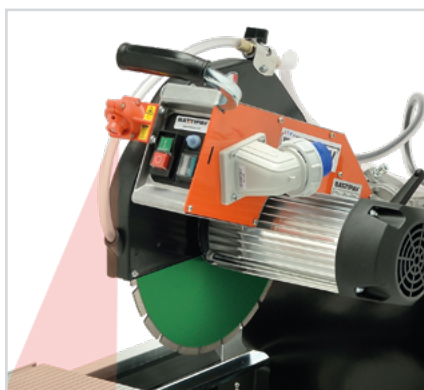

CONTROL BOARD

- Switch with release coil
- Overheat protection with manual reset
- Laser instrument

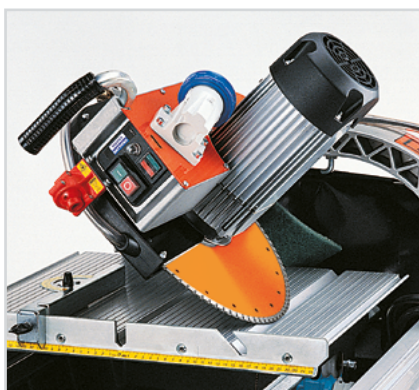

45° CUT

Position 45° angle cuts with relative tilting of the cutting head.



STORAGE

It was designed to reduce overall dimensions during transport and above all the storage space.

/Technical Info



ARTICLE	Technical info										Packaging info	
ELITE 80S (Art. 9001)	3Hp / 2,2Kw, 9A	13 A	2800	350 mm / 25,4 mm	800 mm	435 x 435 mm	110 mm	130 mm	80 mm	442 x 520 mm	80x120 x 97 cm	80x120 x 226 cm





ELITE 80

DO YOU WANT MORE INFO? CHECK THE BATTIPAV WEBSITE AT THIS LINK:
www.battipav.com or write us at sales@battipav.com

/Fittings

	ART.	DESCRIPTION		
	90102R 90176R	KIT WHEELS SWIVEL WHEELS KIT	1	4,9 6,6
	SP90159	CEE SOCKET 230V + CABLE 3MT. + SHUKO PLUG	1	0,6
	TNSP350W	DIAMOND DISK Ø350 TILE, GRES, PREMIUM, WET	1	1,4
	TNSB350W	DIAMOND DISK Ø350 GRES/MARBLE/GRANITE, TURBO BESTEVER, WET	1	1,4
	UNS350W	DIAMOND DISK Ø350 LASER UNIVERSAL, WET	1	1,6
	90180	LIFTING BELT	1	0,9
	P2	WATER PUMP TYPE P2	12	13,6
	71819	PALLET 80X120 CM	1	20,0

/Price list

ARTICLE	DESCRIPTION	PHASE	KG
9001	Elite 80S *		73,0
* With Laser And Wheels		 = 230V. 50/60Hz. (3Hp/2Kw)	

ELITE 80

LASER

Laser instrument for the maximum cutting precision.

WORKING TABLE

In aluminium draw-plate with grooves 10 mm wheelbase whose measure corresponds to that of the graduated scale fixed on the supporting rod.

STRUCTURE

The structure is made of aluminum to ensure rigidity and lightness at the same time.



EGO+PLUS



WATCH NOW ▶



/Description



Ego Plus is the classic masonry saw for the building sector.

It is essential in the design, compact and strong. It's suitable for cutting bricks, stones, concrete blocks, granite, marble, natural stones and porcelain tiles. It cuts by pushing the sliding working table or plunging the cutting head. The cutting head turns to 45° and it is equipped with wheels in order to ensure an easy transport. It is designed to work with disks Ø350 and Ø300 mm.

/Caratteristiche

- Amperometric protection
- Overheat protection with manual reset
- Adjustable cutting head
- Sliding working table
- Water recycling pump type P0

/Trademarks

-  TT-Power
-  Spray System
-  AxT

/Range

- Ego Plus

/Features



SPRAY SYSTEM

Patented system that improves the lubrication of diamond discs and ensures higher cutting performance and longer-lasting blades.



TRANSPORT WHEELS

Easy to storage and transport. Wheels are included.



STORAGE

It was designed to reduce overall dimensions during transport and above all the storage space.



45° CUT

Cutting head turning at 45°.

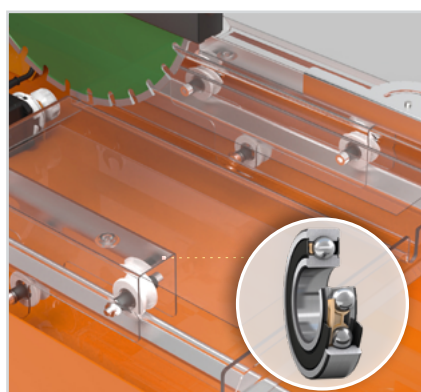

WORKING TABLE

Working table with sliding carriage equipped with 6 adjustable nylon wheels and 8 ball-bearings to get a perfect precision, stability and sliding.



TITLING CUTTING HEAD

For greater rapidity and precision in the execution of particular cuts. It can be locked at the wished height.

/Technical Info

ARTICLE	Technical info										Packaging info	
EGO PLUS (Art. 8000J)	3Hp / 2,2Kw, 9A	13 A	2800	350 mm / 25,4 mm 300 mm / 25,4 mm	800 mm	405x405 mm 230x230 mm	110 mm 80 mm	125 mm	80 mm 60 mm	500x 445 mm	66x115 x 63,5 cm	72x116 x 214 cm



EGO PLUS

DO YOU WANT MORE INFO? CHECK THE BATTIPAV WEBSITE AT THIS LINK:
www.battipav.com or write us at sales@battipav.com

/Fittings

	ART.	DESCRIPTION		
	SP90159	CEE SOCKET 230V + CABLE 3MT. + SHUKO PLUG	1	0,6
	90180	LIFTING BELT	1	0,9
	P0	Water Pump type P0	12	11,9
	TNSP300W	DIAMOND DISK Ø300 TILE, GRES, PREMIUM, WET	1	0,9
	TNSP350W	DIAMOND DISK Ø350 TILE, GRES, PREMIUM, WET	1	1,4
	TNSB300W	DIAMOND DISK Ø300 GRES/MARBLE/GRANITE, TURBO BESTEVER, WET	1	0,9
	TNSB350W	DIAMOND DISK Ø350 GRES/MARBLE/GRANITE, TURBO BESTEVER, WET	1	1,4
	UNS300W	DIAMOND DISK Ø300 LASER UNIVERSAL, WET	1	1,2
	UNS350W	DIAMOND DISK Ø350 LASER UNIVERSAL, WET	1	1,8
	00034	Pallet 72x110 cm	1	10,0

/Price list

ARTICLE	DESCRIPTION	PHASE	KG
8000J	Ego Plus ***	ⓂIF	62,5
***With Wheels		ⓂIF = 230V. 50/60Hz. (3Hp/2,2Kw)	

TILTING CUTTING HEAD

Tilting cutting head for a greater rapidity and precision in the execution of particular cuts. It can be locked at the wished height.

CUTTING BLADE ADJUSTMENT

The cutting head can be adjusted in height in order to mount Ø300 or Ø350 mm diamond blades.

WORKING TABLE

Working table with sliding carriage equipped with 6 adjustable nylon wheels and 8 ball-bearings to get a perfect precision, stability and sliding.

LEGS

Easy system to lock the legs, inclined on the ground for a greater machine stability.

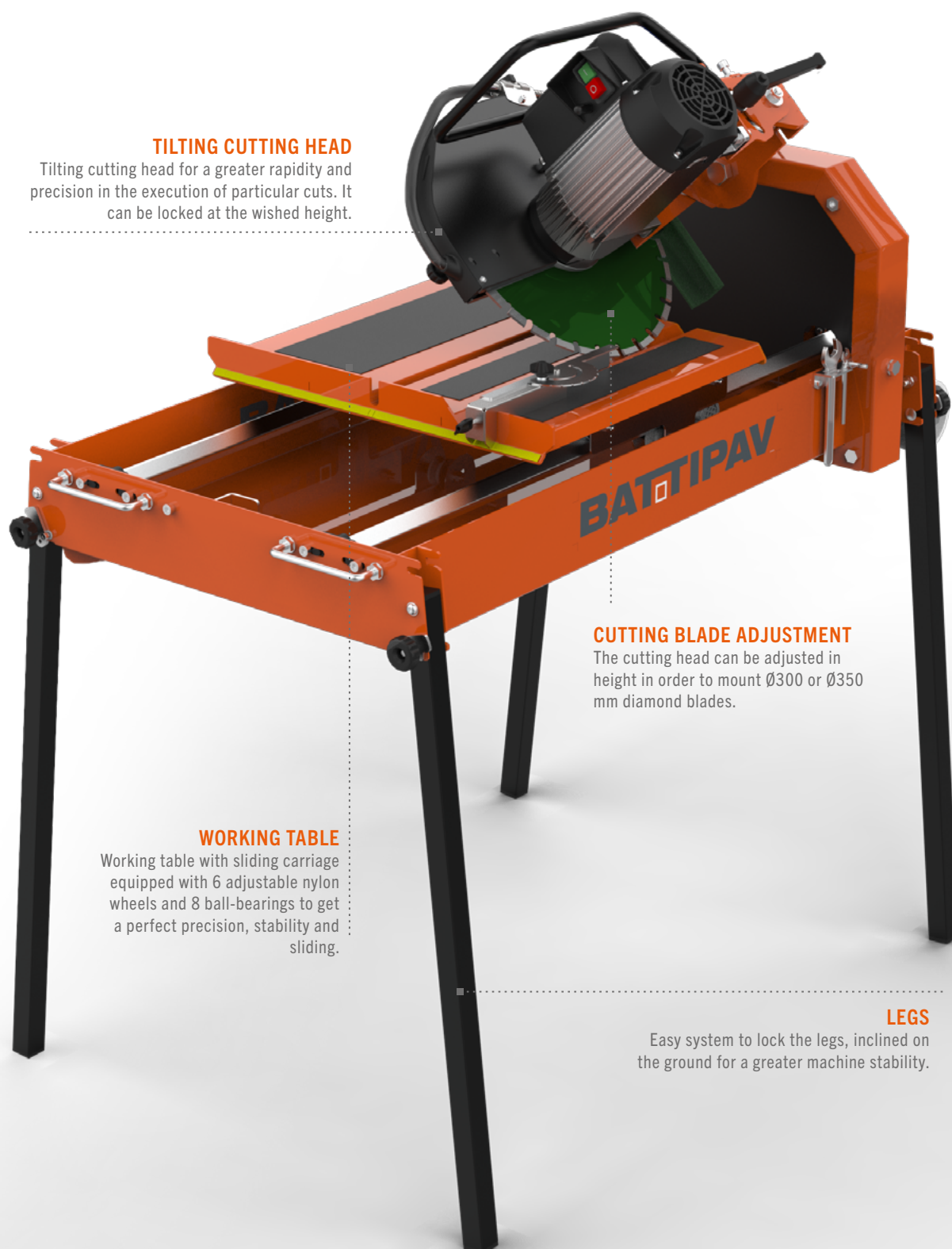

PRIME



WATCH NOW ▶







/Description

Prime is a bridge saw ideal for the building sector. New design with vanguard technical innovation, strong and precise. It's suitable for cutting bricks, stones, concrete blocks, granite, marble, slabs. It cuts by moving forward manually the motor group. It is designed to work with diamond disks Ø350 mm. Laser instrument and kit wheels are supplied as standard.

/Caratteristiche

- Amperometric protection
- Overheat protection with manual reset
- Sliding cutting head and tilting motor
- Cutting progress system with hand wheel
- Water recycling pump type P3
- 45° jolly cut

/Trademarks

-  TT-Power
-  FastLeg
-  Spray System
-  Wdec
-  AxT

/Range

- Prime 200S
- Prime 150S
- Prime 120S
- Prime 100S
- Prime 85S

/Features



ELECTRIC MACHINES

PRIME

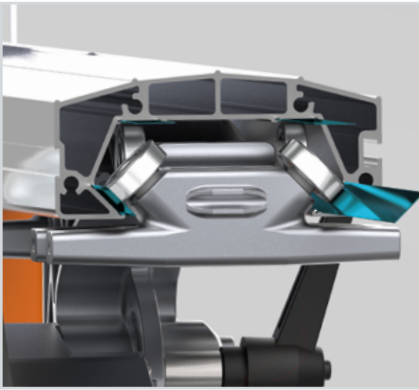

RAIL

The rail is equipped with interchangeable **STAINLESS STEEL** track for a perfect sliding of the motor group carriage.

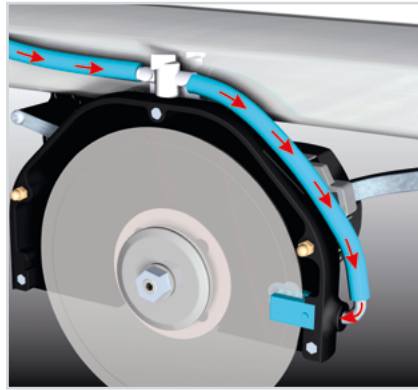

SPRAY SYSTEM

Patented system that improves the lubrication of diamond discs and ensures higher cutting performance and longer-lasting blades.

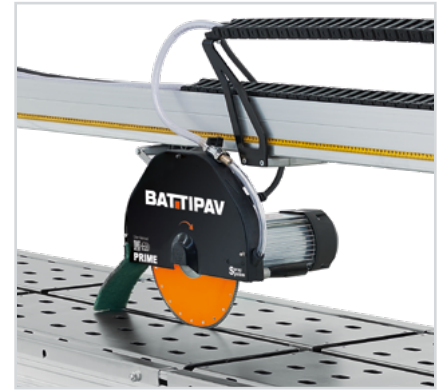

CABLE CHAIN

The system of the cable chain improves the ergonomics of the machine and its disk water cooling. Only for model 150 / 200.



CARRIAGE

The carriage motor group slides with 8 ball bearings on an interchangeable stainless steel track.

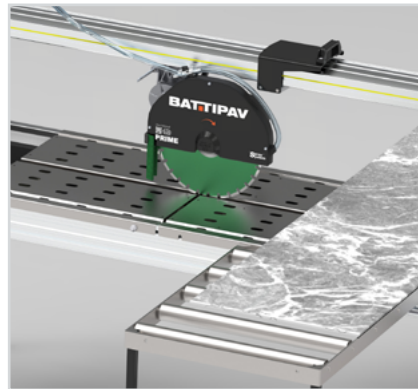

OPTIONAL EXTENSION SIDE BENCH

Available for PRIME, SUPREME, EXTRA SUPER-LUNGA and DYNAMIC 1200 | Art. 90258C



STORAGE

It was designed to reduce overall dimensions during transport and above all the storage space.

/Technical Info

ARTICLE	Technical info										Packaging info	
PRIME 200S (Art. 92001)	3Hp / 2,2Kw, 9A	13 A	2800	350 mm / 25,4 mm	2000 mm	1410 x 1410 mm	110 mm	180 mm	80 mm	2055 x 625 mm	72x275 x 100 cm	72x275 x 226 cm
PRIME 150S (Art. 91501)	3Hp / 2,2Kw, 9A	13 A	2800	350 mm / 25,4 mm	1500 mm	1060 x 1060 mm	110 mm	180 mm	80 mm	1485 x 625 mm	72x225 x 100 cm	72x225 x 226 cm
PRIME 120S (Art. 91201)	3Hp / 2,2Kw, 9A	13 A	2800	350 mm / 25,4 mm	1200 mm	845 x 845 mm	110 mm	180 mm	80 mm	1185 x 625 mm	72x195 x 100 cm	72x195 x 226 cm
PRIME 100S (Art. 91001)	3Hp / 2,2Kw, 9A	13 A	2800	350 mm / 25,4 mm	1000 mm	705 x 705 mm	110 mm	180 mm	80 mm	855 x 625 mm	72x175 x 100 cm	72x175 x 226 cm
PRIME 85S (Art. 90851)	3Hp / 2,2Kw, 9A	13 A	2800	350 mm / 25,4 mm	850 mm	600 x 600 mm	110 mm	180 mm	80 mm	855 x 625 mm	72x160 x 100 cm	72x160 x 226 cm



PRIME



DO YOU WANT MORE INFO? CHECK THE BATTIPAV WEBSITE AT THIS LINK:
www.battipav.com or write us at sales@battipav.com

PRIME













/Fittings

	ART.	DESCRIPTION		
	90262U	B-LOCK TILE LOCKING SYSTEM FOR MATERIAL THICKNESS UP TO 40 MM	1	1,1
	993N 993/120N 993/60N	B-LUX GRIP FOR ABRASIVE SHEET WITH NEUTRAL TUNGSTEN CARBIDE B-LUX ABRASIVE SHEET WITH TUNGSTEN CARBIDE - GR. 120 B-LUX ABRASIVE SHEET WITH TUNGSTEN CARBIDE - GR. 60	1	0,2 0,09 0,09
	90166/85	CUTTING PROGRESS SYSTEM WITH HAND WHEEL - 85	1	1,0
	90241	EXTENSION SIDE-BENCH 60X50 CM	1	8,5
	90102R	KIT WHEELS	1	4,9
	90176R	2 SWIVEL WHEELS KIT	1	7,0
	90258C	EXTENSION SIDE-BENCH WITH ROLLERS 60X80 CM	1	16,4
	90268	ADDITIONAL LEGS	1	2,0
	90167/200 90167/150 90167/120 90167/100	SIDE TILE SUPPORT - PRIME 200 SIDE TILE SUPPORT - PRIME 150 SIDE TILE SUPPORT - PRIME 120 SIDE TILE SUPPORT - PRIME 100	1	5,8 4,2 3,6 3,2
	90167/85U	UNIVERSAL SIDE TILE SUPPORT - PRIME 85	1	3,4
	90167/15	LONG SLOT FOR SIDE TILE SUPPORT	1	1,7
	SP90159	CEE SOCKET 230V + CABLE 3MT. + SHUKO PLUG	1	0,6
	SP90159/T380	CEE SOCKET 400V + CABLE 3 MT.	1	0,7
	90180	LIFTING BELT	1	0,9
	P3	WATER PUMP TYPE P3	6	8,5
	TNSP350W	DIAMOND DISK Ø350 TILE, GRES, PREMIUM, WET	1	1,4



PRIME

ART.	DESCRIPTION		
	TNSB350W DIAMOND DISK Ø350 GRES/MARBLE/GRANITE, TURBO BESTEVER, WET	1	1,8
	UNS350W DIAMOND DISK Ø350 LASER UNIVERSAL, WET	1	1,4
	70088U UNIVERSAL FRONT HANDLE	1	0,5
	90261 PLUNGING MOTOR HANDLE FOR PRIME / SUPREME	1	0,5
	00036 PALLET 72X275 CM	1	24,0
	00012 PALLET 72X225 CM	1	20,0
	00011 PALLET 72X195 CM	1	17,0
	00019 PALLET 72X175 CM	1	16,0
	00010 PALLET 72X160 CM	1	15,0

/Price list

ARTICLE	DESCRIPTION	INFINITY MOTOR	PHASE	KG
92001	Prime 200S*			143,0
92001/T380S1	Prime Infinity 200S*			138,0
91501	Prime 150S*			127,5
91501/T380S1	Prime Infinity 150S*			122,5
91201	Prime 120S*			105,0
91201/T380S1	Prime Infinity 120S*			99,8
91001	Prime 100S*			97,3
91001/T380S1	Prime Infinity 100S*			92,3
90851	Prime 85S*			85,0

* With Laser And Wheels / ** With Laser / ***With Wheels

 = 230V. 50/60Hz. (3Hp/2,2Kw)  = 400V. 50/60Hz. (4,5Hp/3,4Kw)

/Infinity Motors





>NEW MOTOR GENERATION

A **NEW** three-phase Motor that can be used for **infinite** time. Available on **PRIME** and **SUPREME** range machines.

POWERFUL MOTOR (4,5Hp / 3,4Kw 6A) / **THREE-PHASE MOTOR** 2800 rpm

SUPREME



WATCH NOW ▶







/Description

Supreme is a bridge saw ideal for cutting natural stones, granite and marble slabs. It cuts by moving forward manually the motor group. It is designed to work with diamond disks Ø300 mm. Laser instrument and kit wheels are supplied as standard.

/Characteristics*

- Amperometric protection
- Overheat protection with manual reset
- Sliding cutting head and tilting motor
- Cutting progress system with hand wheel
- Water recycling pump type P3
- 45° jolly cut

/Trademarks

-  TT-Power
-  FastLEG
-  Spray System
-  Wdec
-  AxT

/Range

- Supreme 320S
- Supreme 260S
- Supreme 200S
- Supreme 150S
- Supreme 120S
- Supreme 100S
- Supreme 85S

/Features



ELECTRIC MACHINES

SUPREME

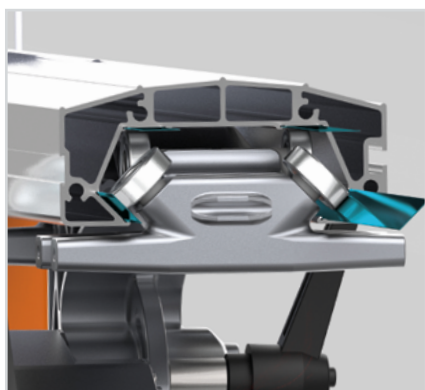

RAIL

The rail is equipped with interchangeable STAINLESS STEEL track for a perfect sliding of the motor group carriage.

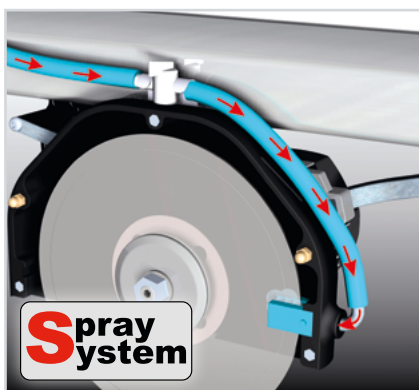

SPRAY SYSTEM

Patented system that improves the lubrication of diamond discs and ensures higher cutting performance and longer-lasting blades.

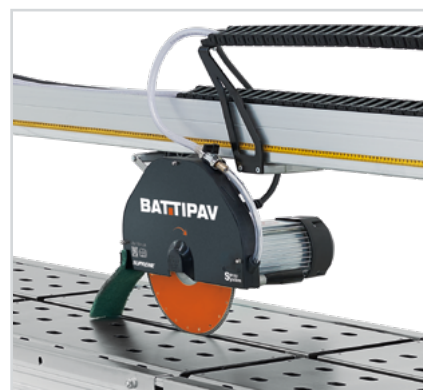

CABLE CHAIN

The system of the cable chain improves the ergonomics of the machine and its disk water cooling. Only for model 150 / 200 / 260 / 320.



CARRIAGE

The carriage motor group slides with 8 ball-bearings on an interchangeable stainless steel track.



OPTIONAL EXTENSION SIDE BENCH

Available for PRIME, SUPREME, EXTRA SUPER-LUNGA and DYNAMIC 1200 | Art. 90258C.



STORAGE

It was designed to reduce overall dimensions during transport and above all the storage space.

/Technical Info

ARTICLE	Technical info										Packaging info	
SUPREME 320S (Art. 83201/T380S1)	4,5Hp / 3,4Kw, 6A	6-10 A	2800	300 mm / 25,4 mm	3200mm	2260 x 2260 mm	85 mm	135 mm	60 mm	3340 x 625 mm	77x366,5 x 141 cm	72x395 x 226 cm
SUPREME 260S (Art. 82601)	3Hp / 2,2Kw, 9A	13 A	2800	300 mm / 25,4 mm	2600 mm	1839 x 1839 mm	85 mm	135 mm	60 mm	2715 x 625 mm	72x340 x 100 cm	72x340 x 226 cm
SUPREME 200S (Art. 82001)	3Hp / 2,2Kw, 9A	13 A	2800	300 mm / 25,4 mm	2000 mm	1410 x 1410 mm	85 mm	135 mm	60 mm	2055 x 625 mm	72x275 x 100 cm	72x275 x 226 cm
SUPREME 150S (Art. 81501)	3Hp / 2,2Kw, 9A	13 A	2800	300 mm / 25,4 mm	1500 mm	1060 x 1060 mm	85 mm	135 mm	60 mm	1485 x 625 mm	72x225 x 100 cm	72x225 x 226 cm
SUPREME 120S (Art. 81201)	3Hp / 2,2Kw, 9A	13 A	2800	300 mm / 25,4 mm	1200 mm	845 x 845 mm	85 mm	135 mm	60 mm	1185 x 625 mm	72x195 x 101 cm	72x195 x 226 cm
SUPREME 100S (Art. 81001)	3Hp / 2,2Kw, 9A	13 A	2800	300 mm / 25,4 mm	1000 mm	705 x 705 mm	85 mm	135 mm	60 mm	855 x 625 mm	72x175 x 100 cm	72x175 x 226 cm
SUPREME 85S (Art. 80851)	3Hp / 2,2Kw, 9A	13 A	2800	300 mm / 25,4 mm	850 mm	600 x 600 mm	85 mm	135 mm	60 mm	855 x 625 mm	72x160 x 100 cm	72x160 x 226 cm

/Fittings

	ART.	DESCRIPTION		
	90262U	B-LOCK TILE LOCKING SYSTEM for material thickness up to 40 mm	1	1,1
	993N 993/120N 993/60N	B-LUX GRIP FOR ABRASIVE SHEET WITH NEUTRAL TUNGSTEN CARBIDE B-LUX ABRASIVE SHEET WITH TUNGSTEN CARBIDE - GR. 120 B-LUX ABRASIVE SHEET WITH TUNGSTEN CARBIDE - GR. 60	1	0,2 0,09 0,09
	90102R	KIT WHEELS	1	4,9
	90176R	2 SWIVEL WHEELS KIT	1	7,0
	90166/85	COMPLETE CUTTING PROGRESS SYSTEM KIT WITH HAND WHEEL - 85	1	1,0
	90241	Extension side-bench 60x50 cm	1	8,5
	90258C	Extension side-bench with rollers 60x80 cm	1	16,4
	90268	ADDITIONAL LEGS	1	2,0
	90167/200 90167/150 90167/120 90167/100	SIDE TILE SUPPORT - SUPREME 200/260/320 SIDE TILE SUPPORT - SUPREME 150 SIDE TILE SUPPORT - SUPREME 120 SIDE TILE SUPPORT - SUPREME 100	1	5,8 4,2 3,6 3,2
	90167/85U	UNIVERSAL SIDE TILE SUPPORT - SUPREME 85	1	3,4
	90167/15	LONG SLOT FOR SIDE TILE SUPPORT	1	1,7
	SP90159	CEE SOCKET 230V + CABLE 3MT. + SHUKO PLUG	1	0,6
	SP90159/T380	CEE socket 400V + cable 3 mt.	1	0,7

	ART.	DESCRIPTION		
	90180	LIFTING BELT	1	0,9
	P3	Water Pump type P3	6	8,5
	TNSP300W	DIAMOND DISK Ø300 TILE, GRES, PREMIUM, WET	1	0,9
	TNSB300W	vDIAMOND DISK Ø300 GRES/MARBLE/GRANITE, TURBO BESTEVER, WET	1	0,9
	UNS300W	DIAMOND DISK Ø300 LASER UNIVERSAL, WET	1	1,2
	70088U	UNIVERSAL FRONT HANDLE	1	0,5
	90261	PLUNGING MOTOR HANDLE FOR PRIME / SUPREME	1	0,5
	00036	Pallet 72x275 cm	1	24,0
	00012	Pallet 72x225 cm	1	20,0
	00011	Pallet 72x195 cm	1	17,0
	00019	Pallet 72x175 cm	1	16,0
	00010	Pallet 72x160 cm	1	15,0
	11201	MULTI BENCH	1	29,34
	11206	MINI MULTI BENCH	1	18,5

/Price list

ARTICLE	DESCRIPTION	INFINITY MOTOR	PHASE	KG
83201/T380S1	Supreme Infinity 320S*			212,5
82601	Supreme 260S*			151,0
82601/T380S1	Supreme Infinity 260S*			151,0
82001	Supreme 200S*			141,0
82001/T380S1	Supreme Infinity 200S*			136,8
81501	Supreme 150S*			125,6
81501/T380S1	Supreme Infinity 150S*			119,0
81201	Supreme 120S*			104,0
81201/T380S1	Supreme Infinity 120S*			99,3
81001	Supreme 100S*			97,2
81001/T380S1	Supreme Infinity 100S*			92,7
80851	Supreme 85S*			93,4
* With Laser And Wheels / ** With Laser / ***With Wheels		= 230V. 50/60Hz. (3Hp/2,2Kw)	= 400V. 50/60Hz. (4,5Hp/3,4Kw)	

*/Included with model: **SUPREME 320S**

- Additional legs (also for the model 260) | Art. 90268
- 2 pcs. B-Lock | Art. 90262U
- Lifting Belt | Art. 90180
- Extension side-bench | Art. 90241
- Extension side-bench with roller | Art. 90268C
- Plunging motor handle | Art. 90261
- Kit Pivoting Wheels | Art. 90176R

/Infinity Motors



infinity

**>NEW MOTOR
GENERATION**

A **NEW** three-phase Motor that can be used for **infinite** time. Available on **PRIME** and **SUPREME** range machines.

POWERFUL MOTOR (4,5Hp / 3,4Kw 6A) / THREE-PHASE MOTOR 2800 rpm

SUPREME

BRIDGE

The rail is an extrusion of aluminium with high resistance to the torsional stress. It's equipped with steel ball bearings running on an interchangeable stainless steel tracks. Absolute cutting precision.

SCALE MEASURE

Millimetres graduated scale for a fast execution of the cuts in series.



STRUCTURE

The structure is made of aluminum to ensure rigidity and lightness at the same time.

DYNAMIC



WATCH NOW ▶







/Description

Dynamic is a bridge saw with antiskid “POLY V” drive belt ideal for the building sector. New design with vanguard technical innovation, strong and precise, it is suitable for cutting bricks, stones, concrete blocks, granite, marble and gres. It cuts by moving forward manually or plunging the motor group. It is designed to work with diamond disks Ø250 mm and Ø300 mm.

/Characteristics

- Amperometric protection
- Overheat protection with manual reset
- Sliding cutting head and tilting motor
- Cutting progress system with hand wheel
- Water recycling pump type P3
- 45° jolly cut

/Trademarks

-  TT-Power
-  FastLeg
-  Spray System
-  Wdec
-  AxT

/Range

- Dynamic 1200S

DYNAMIC

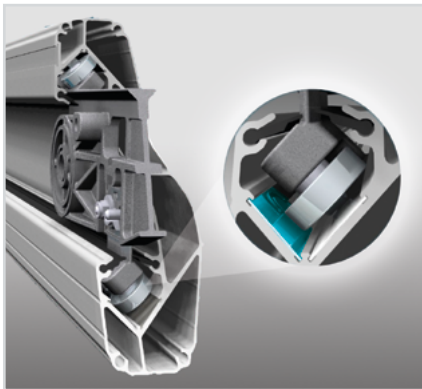

RAIL

The rail is equipped with interchangeable STAINLESS STEEL track for a perfect sliding of the motor group carriage.

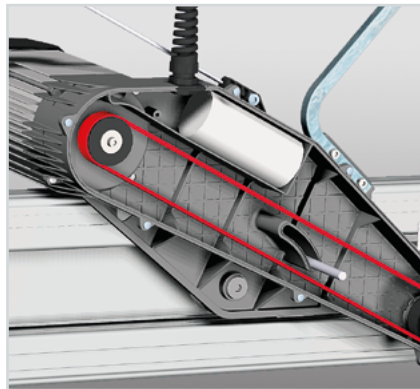

TRANSMISSION

Antiskid FLEXONIC® "POLY V" belt; 24.000 hours without maintenance.



OPTIONAL LONG SLOT SUPPORT

The long slot are necessary to use the side tile support with the extension side table.



PLUNGING HEAD

The cutting head is plunging and can be locked at the intended height. It makes every kind of shape.



CARRIAGE

The carriage motor group slides on the rail by means 6 ball-bearings. The sliding is very fast and precise.



STORAGE

It was designed to reduce overall dimensions during transport and above all the storage space.

/Technical Info

ARTICLE	Technical info										Packaging info	
DYNAMIC 1200S (Art. 701201)	3Hp / 2,2Kw, 9A	13 A	2800	300 mm / 25,4 mm	1200 mm	850x850 mm	110 mm	200 mm	65 mm	1185 x 625 mm	72x195 x 101 cm	72x195 x 178 cm



DYNAMIC

DO YOU WANT MORE INFO? CHECK THE BATTIPAV WEBSITE AT THIS LINK:
www.battipav.com or write us at sales@battipav.com

DYNAMIC

/Fittings



	ART.	DESCRIPTION		
	90262U	B-LOCK TILE LOCKING SYSTEM for material thickness up to 40 mm	1	1,1
	90102R	KIT WHEELS - DYNAMIC 1200	1	4,9
	90176R	2 SWIVEL WHEELS KIT - DYNAMIC 1200	1	7,0
	90241	EXTENSION SIDE-BENCH 60X50 cm - DYNAMIC 1200	1	8,5
	90258C	EXTENSION SIDE-BENCH WITH ROLLERS 60X80 cm - DYNAMIC 1200	1	16,4
	90167/120	SIDE TILE SUPPORT - DYNAMIC 1200	1	3,6
	90167/15	LONG SLOT FOR SIDE TILE SUPPORT	1	1,7
	SP90159	CEE SOCKET 230V + CABLE 3MT. + SHUKO PLUG	1	0,6
	90180	LIFTING BELT	1	0,9
	P3	WATER PUMP TYPE P3	6	8,5
	TNSP250W	DIAMOND DISK Ø250 TILE, GRES, PREMIUM, WET	1	0,5
	TNSP300W	DIAMOND DISK Ø300 TILE, GRES, PREMIUM, WET	1	0,9
	TNB250W	DIAMOND DISK Ø250 GRES/MARBLE/GRANITE, TURBO BESTEVER, WET	1	0,6

DYNAMIC

	ART.	DESCRIPTION		
	TNSB300W	DIAMOND DISK Ø300 GRES/MARBLE/GRANITE, TURBO BESTEVER, WET	1	0,9
	70088U	UNIVERSAL FRONT HANDLE	1	0,5
	00011	Pallet 72x195 cm	1	17,0
	11201	MULTI BENCH	1	29,34
	11206	MINI MULTI BENCH	1	18,5

ELECTRIC MACHINES

/Price list

ARTICLE	DESCRIPTION	PHASE	KG
701201	Dynamic 1200S*		85,0
* With Laser And Wheels		 = 230V. 50/60Hz. (3Hp/2,2Kw)	

EXTRA SUPERLUNGA







/Description

Extra 3300s Superlunga is a bridge saw ideal for straight and 45° angle cuts on oversize porcelain tiles. A new designed bridge profile with vanguard technical innovation, strong and precise, it is equipped with a POWERFUL MOTOR, sliding and plunging cutting head. It is designed to work with diamond disks Ø200 mm special gres (included).

/Characteristics

- 4 Extension side-bench
- Sliding cutting head and plunging motor
- Thermal protection
- Pump P1
- Disk Ø 200 rim cutter included Art.TNSP200W

/Trademarks

-  TT-Power
-  FastLeg
-  Spray System
-  Wdec
-  AxT

/Range

- Extra Superlunga 3300S

/Features



45°

ELECTRIC MACHINES

EXTRA
SUPERLUNGA

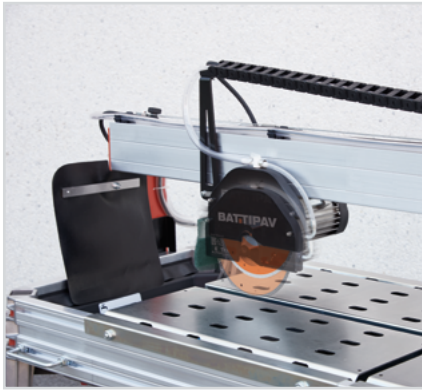

PLUNGING HEAD

The cutting head is plunging and can be locked at the intended height. It makes every kind of shape.

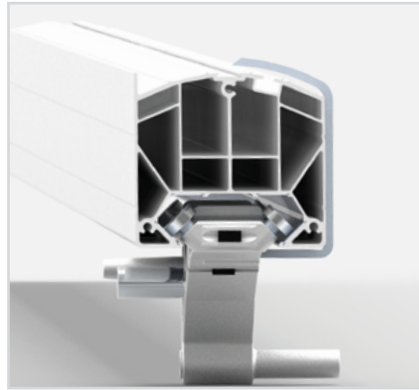

BRIDGE

The rail is an extrusion of aluminium with high resistance to the torsional stress.

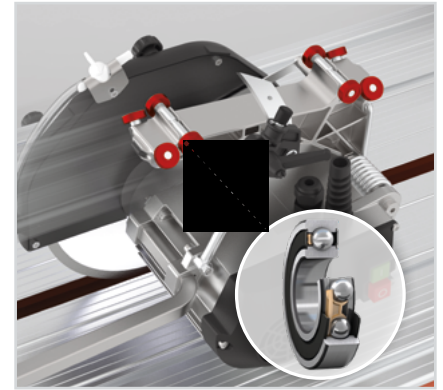

CARRIAGE

The carriage motor group slides with 8 ball-bearings on an interchangeable stainless steel track.



CUTTING PROGRESS SYSTEM

The cutting progress system with handwheel adjusts the movement of the cutting head forward or behind.



B-LOCK TILE LOCKING SYSTEM

A smart device to block the material during the cutting operations.

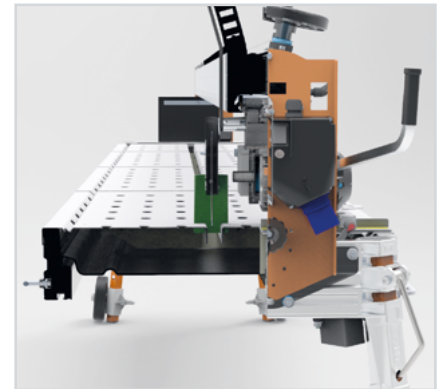

STRUCTURE

The structure is made of aluminum to ensure rigidity and lightness at the same time.

ELECTRIC MACHINES

/Technical Info



ARTICLE	Technical info										Packaging info	
EXTRA 3300S (Art. 6733001)	1,8HP / 1,4KW	13 A	2800	200 mm / 25,4 mm	3300 mm	2330 x 2330 mm	40 mm	55 mm	35 mm	3345 x 624 mm	397,5x72 x 97 cm	395x72 x 222 cm



EXTRA
SUPERLUNGA



DO YOU WANT MORE INFO? CHECK THE BATTIPAV WEBSITE AT THIS LINK:
www.battipav.com or write us at sales@battipav.com

/Fittings

	ART.	DESCRIPTION		
	90262U	B-LOCK TILE LOCKING SYSTEM FOR MATERIAL THICKNESS UP TO 40 MM	1	1,1
	993N 993/120N 993/60N	B-LUX GRIP FOR ABRASIVE SHEET WITH NEUTRAL TUNGSTEN CARBIDE B-LUX ABRASIVE SHEET WITH TUNGSTEN CARBIDE - GR. 120 B-LUX ABRASIVE SHEET WITH TUNGSTEN CARBIDE - GR. 60	1	0,2 0,09 0,09
	SP07060	STONE DRESSER FOR DIAMOND TOOLS	1	0,2
	70102R	KIT WHEELS	1	4,0
	90176R	2 SWIVEL WHEELS KIT	1	7,0
	90241	EXTENSION SIDE-BENCH 60X50 CM	1	8,5
	90258C	EXTENSION SIDE-BENCH WITH ROLLERS 60X80 CM	1	16,4
	90268	ADDITIONAL LEGSS FOR FRAME	1	2,0
	SP0502	EXTENSION CABLE 10 MT. WITH PLUG+SHUKO SOCKET	1	0,6
	90180	LIFTING BELT	1	0,9
	P1	WATER PUMP TYPE P1	12	13,4
	TNSP200W	DIAMOND DISK Ø200 TILE, GRES, PREMIUM	1	0,4
	890SKC	DIAMOND DISK SANKYO Ø200 C/C GRES/GLASS WITH FLANGE	1	0,5

	ART.	DESCRIPTION		
	00043	PALLET 72X395 CM	1	24,0
	67024	KIT ACCESSORIES - EXTRA 3300 SUPERLUNGA 1x ART. 90180 - 1x ART. 890SKC - 1x SP07060 1x ART. 993N - 1x ART. 993/120N	1	3,7

/Price list

ARTICLE	DESCRIPTION	PHASE	KG
6733001	Extra 3300S Superlunga*		181,0
* With Laser And Wheels		 = 230V. 50/60Hz. (1,8Hp/1,4Kw)	

ELECTRIC MACHINES

CLASSplus



WATCH NOW ▶







/Description

Class Plus is a radial tile cutter ideal for straight and 45° angle cuts on porcelain stoneware, tiles and marble. New design with vanguard technical innovation, strong and precise, it is equipped with POWERFUL MOTOR sliding cutting head and plunging motor. It is designed to work with diamond disks Ø250 mm special gres.

/Caratteristiche

- Sliding cutting head and plunging motor
- Thermal protection
- Pump P0
- Pump P1/4 for model 1300S
- Disk Ø 250 special gres included

/Trademarks

-  TT-Power
-  FastLeg
-  Spray System
-  Wdec
-  AxT

/Range

- Class Plus 1300S
- Class Plus 1100S
- Class Plus 850S

/Features



ELECTRIC MACHINES

CLASSplus

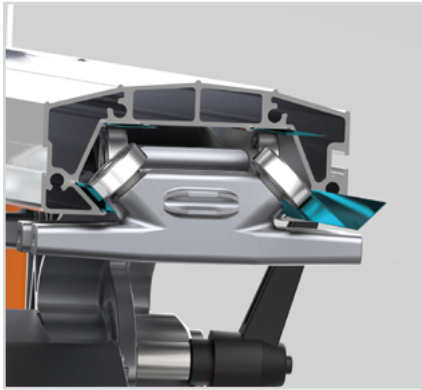

RAIL

The rail is equipped with interchangeable STAINLESS STEEL track for a perfect sliding of the motor group carriage.

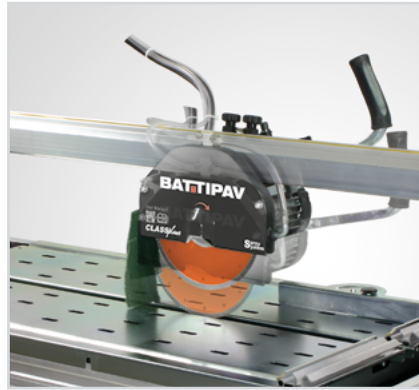

PLUNGING HEAD

The cutting head is plunging and can be locked at the intended height. It makes every kind of shape.

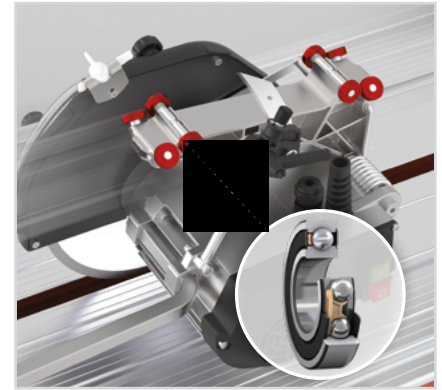

CARRIAGE

The carriage motor group slides with 8 ball bearings on an interchangeable stainless steel track.



45° CUT

Position 45° angle cuts.



OPTIONAL EXTENSION SIDE BENCH

It is very useful when cutting large size tiles and marble slabs.



BRIDGE

The rail is an extrusion of aluminium with high resistance to the torsional stress.

/Technical Info

ARTICLE	Technical info										Packaging info		
CLASS PLUS 1300S (Art. 661351)	1,8Hp / 1,4Kw, 6A	2800	250 mm / 25,4 mm	1160 mm	1300 mm	820 x 820 mm	920 x 920 mm	65 mm	80 mm	53 mm	1354 x 523 mm	72x195 x 94 cm	72x195 x 213 cm
CLASS PLUS 1100S (Art. 661101)	1,8Hp / 1,4Kw, 6A	2800	250 mm / 25,4 mm	910 mm	1050 mm	645 x 645 mm	740 x 740 mm	65 mm	80 mm	53 mm	1084 x 523 mm	72x160 x 94 cm	72x160 x 213 cm
CLASS PLUS 850S (Art. 66901)	1,8Hp / 1,4Kw, 6A	2800	250 mm / 25,4 mm	710 mm	850 mm	500 x 500 mm	600 x 600 mm	65 mm	80 mm	53 mm	882 x 523 mm	72x130 x 94 cm	72x130 x 213 cm









CLASSplus

DO YOU WANT MORE INFO? CHECK THE BATTIPAV WEBSITE AT THIS LINK:
www.battipav.com or write us at sales@battipav.com

	ART.	DESCRIPTION		
	90262U	B-LOCK TILE LOCKING SYSTEM FOR MATERIAL THICKNESS UP TO 40 MM	1	1,1
	SP07060	STONE DRESSER FOR DIAMOND TOOLS	1	0,2
	993N 993/120N 993/60N	B-LUX GRIP FOR ABRASIVE SHEET WITH NEUTRAL TUNGSTEN CARBIDE B-LUX ABRASIVE SHEET WITH TUNGSTEN CARBIDE - GR. 120 B-LUX ABRASIVE SHEET WITH TUNGSTEN CARBIDE - GR. 60	1	0,2 0,09 0,09
	70102R	KIT WHEELS	1	4,0
	70241	EXTENSION SIDE-BENCH 60X50 CM	1	9,0
	90167/85U	UNIVERSAL SIDE TILE SUPPORT - CLASS PLUS 850 - 1050 - 1300	1	3,4
	90167/15	LONG SLOT FOR SIDE TILE SUPPORT	1	1,7
	65030/1300 65030/1050 65030/850	TILE LOCK SYSTEM CLASS PLUS 1300 TILE LOCK SYSTEM CLASS PLUS 1050 TILE LOCK SYSTEM CLASS PLUS 850	1	3,4 2,9 2,7
	SP0502	EXTENSION CABLE 10 MT. WITH PLUG+SHUKO SOCKET	1	1,2
	90180	LIFTING BELT	1	0,9
	P0 P1/4	WATER PUMP TYPE P0 WATER PUMP P1/4 230V./50-60HZ. CABLE 4MT	12 6	11,9 7,5
	TNSP250W	DIAMOND DISK Ø250 TILE, GRES, PREMIUM, WET	1	0,5

	ART.	DESCRIPTION		
	TNSB250W	DIAMOND DISK Ø250 GRES/MARBLE/GRANITE, TURBO BESTEVER, WET	1	0,6
	70088U	UNIVERSAL FRONT HANDLE	1	0,5
	00011	PALLET 72X195 CM	1	17,0
	00010	PALLET 72X160 CM	1	15,0
	00020	PALLET 72X130 CM	1	13,0

/Price list

ARTICLE	DESCRIPTION	PHASE	POWER SUPPLY	KG
661351	CLASS PLUS 1300S*			58,5
661101	CLASS PLUS 1050S*			52,0
66901	CLASS PLUS 850S*			48,5
*With Laser And Wheels			 = 230V. 50/60Hz. (1,8Hp/1,4Kw)	

CLASS



WATCH NOW ▶







/Description

Class is a radial tile cutter ideal for straight and 45° angle cuts on porcelain stoneware, tiles and marble. New design with vanguard technical innovation, strong and precise, it is equipped with sliding cutting head and plunging motor. It is designed to work with diamond disks Ø200 mm special gres.

/Caratteristiche

- Sliding cutting head and plunging motor
- Thermal protection
- Pump P0
- Disk Ø 200mm special gres (included)

/Trademarks

-  TT-Power
-  FastLeg
-  Spray System
-  Wdec
-  AxT

/Range

- Class 1100S
- Class 900S
- Class 670S

/Features

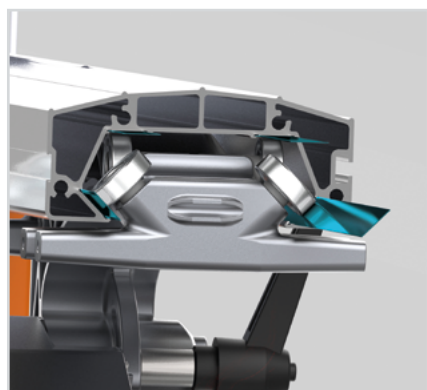

RAIL

The rail is equipped with interchangeable **STAINLESS STEEL** track for a perfect sliding of the motor group carriage.



PLUNGING HEAD

The cutting head is plunging and can be locked at the intended height. It makes every kind of shape.



STRUCTURE

The structure is made of aluminum to ensure rigidity and lightness at the same time.



OPTIONAL B-LOCK TILE LOCKING SYSTEM

A smart device to block the material during the cutting operations | Art. 90262U



OPTIONAL EXTENSION SIDE BENCH

It is very useful when cutting large size tiles and marble slabs. | Art. 70241

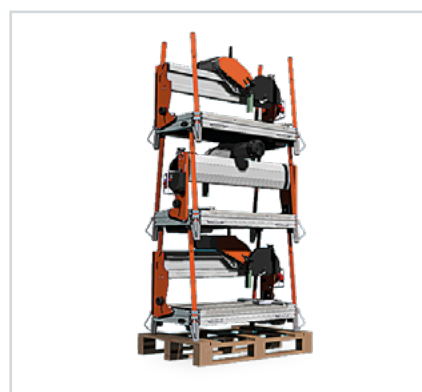

STORAGE

It was designed to reduce overall dimensions during transport and above all the storage space.

/Technical Info

ARTICLE	Technical info									Packaging info	
CLASS 1100S (Art. 651101)	1,3Hp / 1,0Kw, 4,5A	2800	200 mm / 25,4 mm	1100 mm	775 x 775 mm	40 mm	55 mm	40 mm	1084 x 523 mm	72x160 x 94 cm	72x160 x 213 cm
CLASS 900S (Art. 65901)	1,3Hp / 1,0Kw, 4,5A	2800	200 mm / 25,4 mm	900 mm	635 x 635 mm	40 mm	55 mm	40 mm	882 x 523 mm	72x130 x 94 cm	72x130 x 213 cm
CLASS 670S (Art. 65671)	1,3Hp / 1,0Kw, 4,5A	2800	200 mm / 25,4 mm	670 mm	470 x 470 mm	40 mm	55 mm	40 mm	652 x 523 mm	72x110 x 94 cm	72x110 x 213 cm



CLASS

DO YOU WANT MORE INFO? CHECK THE BATTIPAV WEBSITE AT THIS LINK:
www.battipav.com or write us at sales@battipav.com







/Fittings

	ART.	DESCRIPTION		
	90262U	B-LOCK TILE LOCKING SYSTEM FOR MATERIAL THICKNESS UP TO 40 MM	1	1,1
	SP07060	STONE DRESSER FOR DIAMOND TOOLS	1	0,2
	993N 993/120N 993/60N	B-LUX GRIP FOR ABRASIVE SHEET WITH NEUTRAL TUNGSTEN CARBIDE B-LUX ABRASIVE SHEET WITH TUNGSTEN CARBIDE - GR. 120 B-LUX ABRASIVE SHEET WITH TUNGSTEN CARBIDE - GR. 60	1	0,2 0,09 0,09
	70102R	KIT WHEELS	1	4,0
	70241	EXTENSION SIDE-BENCH 60X50 CM	1	9,0
	90167/85U	UNIVERSAL SIDE TILE SUPPORT - CLASS PLUS 850 - 1050 - 1300	1	3,4
	90167/15	LONG SLOT FOR SIDE TILE SUPPORT	1	1,7
	65030/1100 65030/900 65030/670	TILE LOCKING SYSTEM FOR CLASS 1100 TILE LOCKING SYSTEM FOR CLASS 900 - 900S TILE LOCKING SYSTEM FOR CLASS 670	1	2,9 2,8 2,5
	SP0502	EXTENSION CABLE 10 MT. WITH PLUG+SHUKO SOCKET	1	1,2
	90180	LIFTING BELT	1	0,9
	P0	WATER PUMP TYPE P0	12	11,9
	TNSP200W	DIAMOND DISK Ø200 TILE, GRES, PREMIUM, WET	1	0,5

/Price list

	ART.	DESCRIPTION		
	TNSB200W	DIAMOND DISK Ø20 0 GRES/MARBLE/GRANITE, TURBO BESTEVER, WET	1	0,6
	70088U	UNIVERSAL FRONT HANDLE	1	0,5
	00010	PALLET 72X160 CM	1	15,0
	00020	PALLET 72X130 CM	1	13,0
	00034	PALLET 72X110	1	10,0

/Price list

ARTICLE	DESCRIPTION	PHASE	POWER SUPPLY	KG
651101	CLASS 1100S*			48,0
65901	CLASS 900S*			46,0
65671	CLASS 670S*			42,5
*With Laser And Wheels			 = 230V. 50/60Hz. (1,3Hp/1Kw)	

VIP



1,8 Hp / 1,4 Kw
POWERFUL AND STRONG MOTOR

WATCH NOW ▶





/Description

Vip is a radial tile cutter ideal for straight and 45° angle cuts on porcelain stoneware, tiles and marble. Strong and precise, it is equipped with sliding cutting head and plunging motor. It is designed to work with diamond disks Ø200 mm.

/Characteristics

- Sliding cutting head and plunging motor
- Foldable legs
- Transport wheels (Vip 2125)
- Pump P0 (Vip 2110, Vip 290, Vip 260); Pump P1/4 (Vip 2125)
- Disk Ø 200 Special gres included (Vip 2125)
- Disk Ø 200 continuous rim included (Vip 2110, Vip 290, Vip 260)

/Trademarks

-  TT-Power
-  Spray System
-  AxT

/Range

- Vip 2125
- Vip 2110
- Vip 290
- Vip 260

/Features

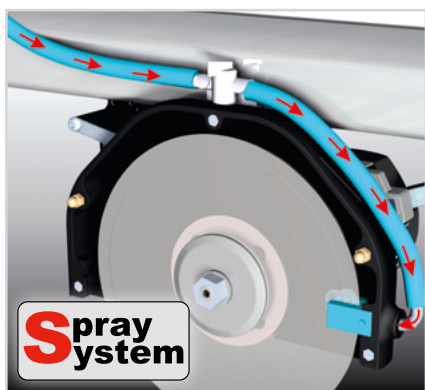

SPRAY SYSTEM

Patented system that improves the lubrication of diamond discs and ensures higher cutting performance and longer-lasting blades.

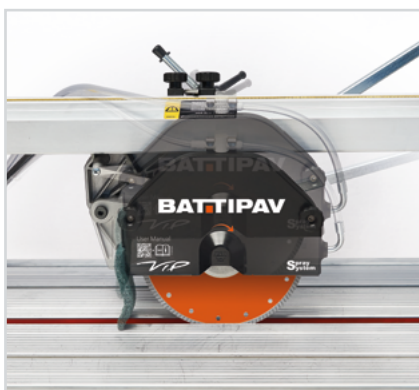

PLUNGING HEAD

The cutting head is plunging and can be locked at the intended height. It makes every kind of shape.

ELECTRIC MACHINES

VIP



FRAME AND WORKTOP

The frame and the worktop in aluminium are wider to allow greater stability and precision during the cut. The special shape of the worktop allows an easy cleaning. Only for Art. 857.

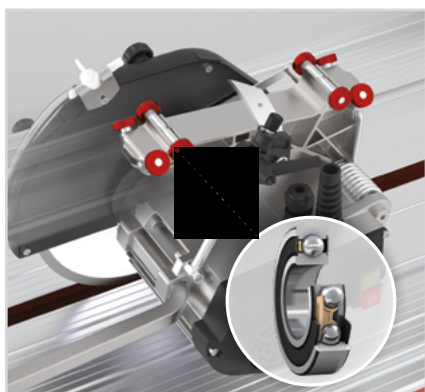

CARRIAGE MOTOR GROUP

The carriage motor group slides with 6 ball-bearings (2 of which are adjustable) on the track. The sliding is very fast and precise. Only for Art. 857.



OPTIONAL EXTENSION SIDE BENCH

It is very useful when cutting large size of tiles and marble slabs.



TRANSPORT WHEELS

Easy to carriage. Only for Art. 857.

/Technical Info

ARTICLE	Technical info									Packaging info		
VIP 2125 (Art. 857)	1,8Hp / 1,4Kw,6A	2800	200 / 25,4 mm	1250 mm	880 x 880 mm	40 mm	55 mm	35 mm	1170 x 520 mm	170x70,5 x 51 cm	4 pcs	175x72 x 219 cm
VIP 2110 (Art. 856)	1,3Hp / 1,0Kw,4,5A	2800	200 / 25,4 mm	1100 mm	775 x 775 mm	40 mm	55 mm	40 mm	1070 x 403 mm	148x57 x 50 cm	8 pcs	114x150 x 210 cm
VIP 290 (Art. 855)	1,3Hp / 1,0Kw,4,5A	2800	200 / 25,4 mm	900 mm	635 x 635 mm	40 mm	55 mm	40 mm	915 x 403 mm	127x57 x 50 cm	8 pcs	116x128 x 210 cm
VIP 260 (Art. 850)	1,3Hp / 1,0Kw,4,5A	2800	200 / 25,4 mm	600 mm	420 x 420 mm	40 mm	55 mm	40 mm	600 x 403 mm	96x57 x 50 cm	8 pcs	120x100 x 210 cm













DO YOU WANT MORE INFO? CHECK THE BATTIPAV WEBSITE AT THIS LINK:
www.battipav.com or write us at sales@battipav.com









ELETRIC MACHINES



/Fittings

	ART.	DESCRIPTION		
	90262U	B-LOCK TILE LOCKING SYSTEM for material thickness up to 40 mm ONLY FOR VIP 2125	1	1,1
	SP07060	STONE DRESSER FOR DIAMOND TOOLS	1	0,2
	993N 993/120N 993/60N	B-LUX GRIP FOR ABRASIVE SHEET WITH NEUTRAL TUNGSTEN CARBIDE B-LUX ABRASIVE SHEET WITH TUNGSTEN CARBIDE - GR. 120 B-LUX ABRASIVE SHEET WITH TUNGSTEN CARBIDE - GR. 60	1	0,2 0,09 0,09
	P2/4 P0	WATER PUMP P2/4 230V./50-60HZ. CABLE 4MT., Water Pump type P0	6 12	6,9 11,9
	85015	EXTENSION SIDE-BENCH 60x40 cm	1	5,5
	889	DIAMOND DISK Ø200 C/C	1	0,3
	TNSP200W	DIAMOND DISK Ø200 TILE, GRES, PREMIUM, WET	1	0,4
	TNSB200W	DIAMOND DISK Ø200 GRES/MARBLE/GRANITE, TURBO BESTEVER, WET	1	0,4

/Price list

ARTICLE	DESCRIPTION	PHASE	POWER SUPPLY	KG
857	Vip 2125***			51,5
856	Vip 2110			42,8
855	Vip 290			40,3
850	Vip 260			34,5

* With Laser And Wheels / ** With Laser / ***With Wheels

 = 230V. 50/60Hz. (1,3Hp/1Kw)



PLUNGING HEAD

It can be locked at the wished height.

GONIOMETER FENCE

A professional adjustable goniometer fence is included.



**OPTIONAL CONNECTION FOR
EXTENSION SIDE BENCH**

It is very practical when you need to cut large sizes of tiles. | Art. 85015

QUEEN 180

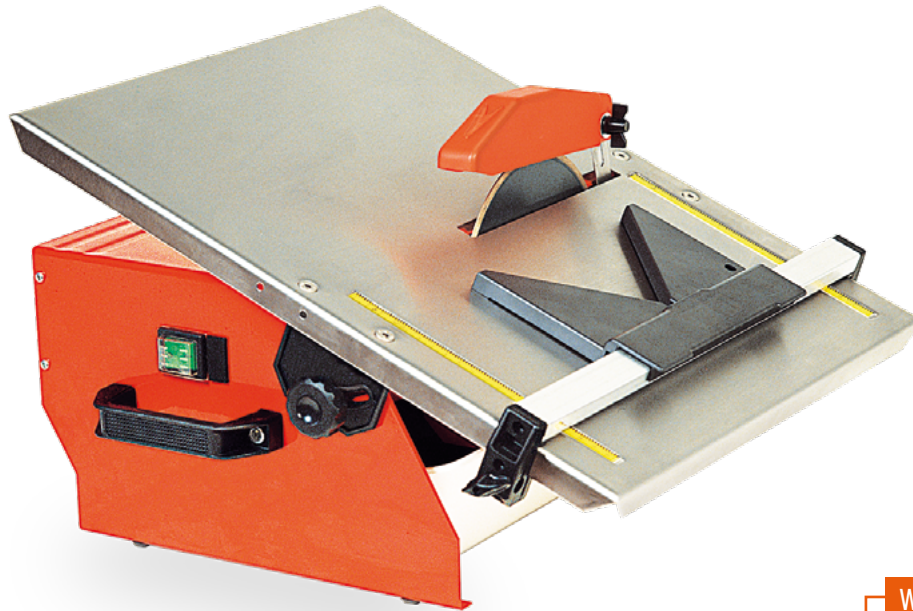

WATCH NOW ▶



/Description

QUEEN 180 is a radial tile cutter ideal for straight and 45° angle cuts on porcelain stoneware, tiles and marble. Strong and precise, it is equipped with sliding cutting head and plunging motor. It is designed to work with diamond disks Ø200 mm.

/Characteristics

- Working table dimension: 475x420 mm
- Fence for diagonal cuts
- Handle for easy transport
- Disk Ø 180 included

/Range

- Queen 180

/Features

ELECTRIC MACHINES

QUEEN 180

45°



TABLE DIMENSION

Working table dimension 475x420 mm. Disk included.

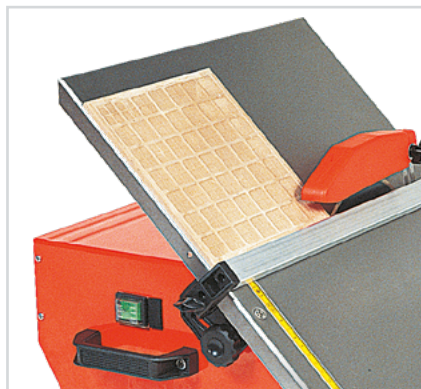

DIAGONAL CUTS

Unlimited 45° angle cuts by placing the glazed side of the tile on working table.



HADLE FOR TRANSPORT

Compact and easy to handle and to transport.

/Technical Info

ARTICLE	Technical info								Packaging info		
											32 pcs
QUEEN 180 (Art. 818)	0,8Hp / 0,55Kw, 2,5A	2800	180 / 25,4 mm	∞	∞	35 mm	25 mm	420 x 475 mm	49x49 x 22 cm	100x100 x 193 cm	

/Fittings



ART.

DESCRIPTION



887

DIAMOND DISK Ø180 C/C

1

0,3

/Price list

ARTICLE	DESCRIPTION	PHASE	POWER SUPPLY	KG
818	QUEEN 180			14,0
			= 230V. 50/60Hz. (1,3Hp/1Kw)	



QUEEN 180 |

DO YOU WANT MORE INFO? CHECK THE BATTIPAV WEBSITE AT THIS LINK:
www.battipav.com or write us at sales@battipav.com

TOOLS FOR BETTER PERFORMANCE



B-LOCK | Art. 90262U

Micrometric adjustable tile locking System

- Adjustable height and pressure (max 40 mm.)
- For all the models



EXTENSION SIDE TABLE WITH ROLLERS | Art. 90258C

Available for **PRIME**, **SUPREME**, **EXTRA SUPERLUNGA** and **DYNAMIC 1200**



EXTENSION SIDE BENCH | Art. 90241

Available for **PRIME**, **SUPREME**, **EXTRA SUPERLUNGA** and **DYNAMIC 1200**



ADDITIONAL LEGS | Art. 90268

Available for **EXTRA SUPERLUNGA**, **PRIME** and **SUPREME**



EXTENSION SIDE-BENCH | Art. 85015

Available for **VIP**



TILE LOCK SYSTEM

Art. 65030/1300 | Art. 65030/1050 | Art. 65030/850

Art. 65030/1100 | Art. 65030/900 | Art. 65030/670

Excellent solution for **CLASS**, **CLASS PLUS**



LONG SLOTS | Art. 90167/15
 Needed when adding the side table
 Available for PRIME, SUPREME, DYNAMIC 1200, CLASS and CLASS PLUS



UNIVERSAL SIDE TILE SUPPORT | Art. 90167/85U
 Very useful side holder for any Bridge Saw
 Available for PRIME, SUPREME, DYNAMIC 1200, CLASS and CLASS PLUS

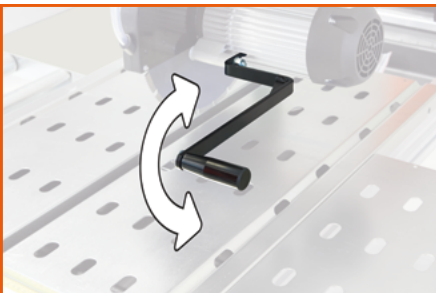

PLUNGING MOTOR HANDLE | Art. 90261
 To be fixed directly on PRIME and SUPREME motor



B-LUX STONE DRESSER
 Perfect to remove chips when cutting very hard tile surfaces

B-LUX GRIP FOR ABRASIVE SHEET | Art. 993N
B-LUX ABRASIVE SHEET | Art. 993/120N
B-LUX ABRASIVE SHEET | Art. 993/60N



JOINT SET | Art. 11205
 Perfect to connect a multipurpose worktable to the electric machine, so it is possible to work better with the large formats



SPACER SUPPORT KIT | Art. SP11026
 Kit of 4 rubber spacers designed to keep the slab up to the bars. They help to create cuts and shapes of all kinds, preserving the integrity of Multi Bench or Mini Multi Bench's bars

Mixer



WATCH NOW ▶



/Description

Mixer is designed specifically to mix perfectly and homogeneously adhesives for tilers, cement, paints and epoxy resins. It works independently merging up to 50 kg of material.

/Characteristics

- PET Bucket - 65 Lt.
- Mixing capacity 50 Kg
- Dedicated whip
- **Safety:** An automatic safety switch prevents the motor to start when the mixing head is completely raised up

/Trademarks

-  TT-Power

/Range

- Mixer 50s

Mixer



USE

The material must be poured directly on the black plastic protection and then centrifuged for the right mixing.



AUTOMATIC MIXING

It mixes up to 50 kg of material independently. Save time and money!



SAFETY

An automatic safety switch prevents the motor to start when the mixing head is completely raised up.



HOMOGENEOUS PASTE

Homogeneous paste and without lumps.



MOTOR

Powerful, it's provided with overheat protection with manual reset. It intervenes in the event of the agitator jamming.



EASY TO HANDLE

The machine is easy to move.

/Technical Info

		Technical info		Packaging info	
ARTICLE					16 pcs
MIXER 50 SUPER (Art. 050S)	1,6 Hp / 1,2 Kw, 7A	60 min ⁻¹	65 L	58x63x50 cm	117x127x215 cm



Mixer



DO YOU WANT MORE INFO? CHECK THE BATTIPAV WEBSITE AT THIS LINK:
www.battipav.com or write us at sales@battipav.com

Mixer

/Fittings

	ART.	DESCRIPTION		
	SP05002	PET BUCKET - 65 L	5	10,0
	SP0502	EXTENSION CABLE 10 MT. WITH PLUG+SHUKO SOCKET	1	1,2

/Price list

ARTICLE	DESCRIPTION	PHASE	POWER SUPPLY	KG
050S	MIXER 50 SUPER*			22,4
* With Whip and Bucket		 = 230V. 50/60Hz. (1,6Hp/1,2Kw)		

/Bucket Internal dimension:



Mixer

MOTOR

Powerful, it's provided with overheat protection with manual reset. It intervenes in the event of the agitator jamming.

BUCKET

Homogeneous paste and without lumps. It mixes up to 50 kgs of material independently.

MIXIT



WATCH NOW ▶



/Description

An innovative Mixer, equipped with a safety stop system and a handy structure. It is anchored to the bucket by 3 hinges, with the whisk designed to mix the most common cementitious materials, such as tile adhesive, screeds, premixed plasters, grouts for joints, and much more. It is also equipped with a trolley, for the transport of the full bucket.

/Characteristics

- PET Bucket - 65 Lt.
- Mixing capacity 50 Kg
- Dedicated whip
- Carriage included
- Automatic switch prevents the motor to start when the mixing head is raised up

/Range

- Mixit



MIXING

Material should be poured directly on the steel cover for the correct mixing.

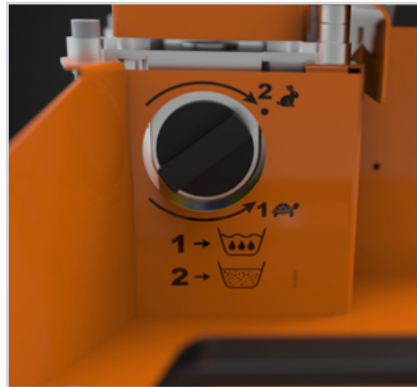

SPEEDS

Two speeds mechanical gear lever.



CARRIAGE INCLUDED

The practical carriage allows to transport easily the bucket full of mixed material on the working site.



SAFETY

A safety switch prevents the motor to start when the mixing head is not in the right position.



WHIP





Dedicated design whip, studied specifically for the perfect mixing of various material, from smooth to rough.



BUCKET

Homogeneous paste and without lumps. It mixes up to 50 kgs of material independently.

/Technical Info

ARTICLE	Technical info			Packaging info	
					 8 pcs
MIXIT (Art. 055)	2,2 Hp / 1,6 Kw	180-360 min ⁻¹	65 L	69x59x45 cm	117x127x215 cm



MIXIT

DO YOU WANT MORE INFO? CHECK THE BATTIPAV WEBSITE AT THIS LINK:
www.battipav.com or write us at sales@battipav.com



/Fittings

	ART.	DESCRIPTION		
	SP05002	PET BUCKET - 65 LT.	5	10,0
	SP05502	WHIP FOR MIXIT	1	3,2
	SP0502	Extension cable 10 mt. with plug+SHUKO socket	1	1,2

/Price list

ARTICLE	DESCRIPTION	PHASE	POWER SUPPLY	KG
055	MIXIT*			21
* With Whip and Bucket		= 230V. 50/60Hz. (2,2Hp/1,6Kw)		

CARRIAGE

Practical carriage allows to transport easily the full bucket of mixed material on the working site.

MOTOR

Powerful, it's provided with overheat protection with manual reset. It intervenes in the event of the agitator jamming.

SPEEDS

Two different speeds gear variator.

BUCKET

Homogeneous paste and without lumps. It mixes up to 50 kgs of material independently

Mini Mix



WATCH NOW ▶



/Description

Mini Mix is a professional mixer for tile adhesives, plaster, cement, chalk and paints.

/Characteristics

- Electronic rotation speed variator up to 6 levels
- Two speeds mechanical gear lever
- Ergonomic handle
- M14x2 connection

/Range

- Mini Mix 1800
- Mini Mix 1300

**SPEED**

Various speeds are available, for a perfect mixing.

**HANDLE**

Ergonomic handle for a comfortable use.

**HELICOIDAL WHIP**

You can use different types of whips, from Ø135 to Ø165.

/Technical Info

ARTICLE	Technical info					Packaging info		
Mini Mix 1800 (Art.4180)	Ø165 mm	140 kg	180 /380 vel. (1)	300 /650 vel. (2)	2,4Hp/1,8Kw	62x30x21 cm	28 pz	80x120x162 cm
Mini Mix 1300 (Art. 4130)	Ø135 mm	50 kg	180 /380	300 /650	1,7Hp/1,3Kw	62x30x21 cm	28 pz	80x120x162 cm

/Fittings

	ART.	DESCRIPTION		
	5131	HELICOIDAL WHIP Ø135 MM - M14 CONNECTION	1	1,2
	5161	HELICOIDAL WHIP Ø165 MM - M14 CONNECTION	1	1,5
	SP05002	PET BUCKET - 65 L	5	10,0

/Price list

ARTICLE	DESCRIPTION	PHASE	POWER SUPPLY	KG
4180	MINI MIX 1800*			6,3
4130	MINI MIX 1300**			5,7

* With Whip Ø165 Mm. ** With Whip Ø135 Mm.

= 230V. 50/60Hz. (1,7Hp/1,3Kw)



MASTER LINDA



WATCH NOW ▶



/Description

MASTER LINDA, the monobrush is a high performance product, suitable for buffing, cleaning, filling, smoothing floors for the construction industry. A full range of accessories to meet all needs.

The machine is arranged for the suction of powders and can be ballasted to increase weight, based on the usage.

/Characteristics

- 8 liters tank
- Two rotation speeds
- Polypropylene brush Ø 500mm included (art. 0959)

/Trademarks

-  TT-Power

/Range

- MasterLinda

MASTER LINDA**POWERFUL MOTOR**

Two rotation speeds.

**BELL**

Made in impact resistant steel, provided with rubber edge and designed for dust aspiration.

**HANDLE INCLINATION**

The adjustment of the handle inclination to the right working position is made by a multi-plate clutch, which is more reliable and secure.

**FOLDABLE HANDLE**

To store the machine in a small space.







**OPTIONAL BALLAST**

The machine can be ballasted with 13 kg. For additional weight, you can add the 22kg ballast to the initial 13kg ballast.

**WATER TANK**

A wide tank for using the machine with liquids and detergents.

/Technical Info

ARTICLE	Technical info					Packaging info	
				 vel. (1)	 vel. (2)		 4 pcs
MASTER LINDA (Art. 0960S)	3,4Hp / 2,5Kw, 10A	8 L	60 / 120 min ⁻¹	60 min ⁻¹ (1,3Hp / 1,0Kw)	120 min ⁻¹ (3,4Hp / 2,5Kw)	69x58x82 cm	72x116x178 cm

**MASTER LINDA**







DO YOU WANT MORE INFO? CHECK THE BATTIPAV WEBSITE AT THIS LINK:
www.battipav.com or write us at sales@battipav.com

MASTER LINDA

/Fittings

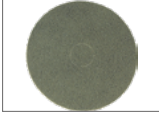

	ART.	DESCRIPTION		
	096079	13 KG SIDE BALLAST TO INCREASE THE GROUND PRESSURE DURING SMOOTHING OPERATIONS	1	13,0
	096078	22 KG SIDE BALLAST TO INCREASE THE GROUND PRESSURE DURING SMOOTHING OPERATIONS CAN BE USED ONLY WITH ART. 096079 AND NOT INDIVIDUALLY!	1	22,0
	0951	PPN STEEL BRUSH Ø480 MM FOR CLEANING FLOOR SURFACES FROM HARD CEMENT	1	4,5
	0954	SHEET DISK WITH ROUNDED RIM Ø600 MM FOR FINISHING CEMENT BASES	1	8,5
	0957	DISK FOR ABRASIVE PAPER Ø500 MM DISK HOLDER FOR SANDING PAPER DISCS AND TUNGSTEN CARBIDE ABRASIVE DISK	1	5,5
	988/1B	WOLFRAM CARBIDE DISK DOUBLE FACE GRAIN 36 Ø500 MM FOR ART. 0957 FOR SANDING AND ABRADING APPLICATIONS OR LIGHT SURFACE PREPARATION	1	0,1
	988/2B	WOLFRAM CARBIDE DISK DOUBLE FACE GRAIN 100 - Ø500 MM FOR ART. 0957 FOR SANDING AND ABRADING APPLICATIONS OR LIGHT SURFACE PREPARATION	1	0,1
	09590/14	TUNGSTEN CARBIDE ABRASIVE DISK GRAIN 14 - Ø500 MM DOUBLE FACE FOR ART. 0957	1	0,1
	09590/24	TUNGSTEN CARBIDE ABRASIVE DISK GRAIN 24 - Ø500 MM DOUBLE FACE FOR ART. 0957	1	0,1
	09590/36	TUNGSTEN CARBIDE ABRASIVE DISK GRAIN 36 - Ø500 MM DOUBLE FACE FOR ART. 0957	1	0,1
	09588	DISK WITH 3 ABRASIVE DISKS GRINDERS 500 MM	1	5,5
	0988K	COMPLETE KIT OF ABRASIVE DISKS Ø178 MM FOR ART. 09588	3	1,5
	0959	PPN BRUSH 0,80X50 Ø500 MM FOR CLEANING NARROW JOINTS FLOORS AFTER THE GROUTING	1	4,5

MASTER LINDA

	ART.	DESCRIPTION		
	0956	FULL VELCRO-DRAWING DISK Ø460 MM DISK HOLDER FOR FELT DISCS	1	3,5
	983/1	BLACK FELT Ø508 MM FOR ART. 0956 MUCH ABRASIVE FOR HEAVY CLEANINGS	5	2,0
	983/2	GREEN FELT Ø508 MM FOR ART. 0956 ABRASIVE FOR NORMAL CLEANINGS	5	2,0
	983/3	BEIGE FELT Ø508 MM FOR ART. 0956 ABRASIVE FOR SOFT CLEANINGS	5	2,0
	983/4	WHITE FELT Ø508 MM FOR ART. 0956 SOFT FOR POLISHING	5	10,0
	09510	SPONGE FOR THE FLOORS WASHING H. 5 Ø508 MM FOR ART. 0956 TO EMULSIFY THE RESIDUE OF CEMENT BASE GROUT AFTER THE GROUTING PHASE	1	0,3
	09589	DISK WITH 6 SILICON CARBIDE GRINDERS 500 MM	1	8,0
	09589K	COMPLETE KIT OF 6 SILICON CARBIDE Ø110 MM GRINDSTONES, FOR ART. 09589	1	4,2

ELECTRIC MACHINES

/Price list

ARTICLE	DESCRIPTION	PHASE	POWER SUPPLY	KG
0960S	MASTER LINDA WITH TANK AND PPN BRUSH Ø500			40,8
			 = 230V. 50/60Hz. (2Hp/1,5Kw)	



/Description

Linda Veloce is a machine for plastering, cleaning, buffing and polishing floors according to the specific accessories.

/Characteristics

- 8 liters tank
- One rotation speeds
- Polypropylene brush Ø 420 included (art. 099)

/Trademarks

-  TT-Power

/Range

- LindaVeloce



POWERFUL MOTOR

One speed for an extremely elevated rotation per minute (207rpm).



HEIGHT HANDLE ADJUSTMENT





The height handle adjustment allows to obtain a perfect working position thanks to a wing nut screw.





HANDLE INCLINATION

The adjustment of the handle inclination to the right working position is made by a multi-plate clutch, which is more reliable and secure.

/Technical Info

ARTICLE	Technical info			Packaging info	
			 min ⁻¹ vel. (l)		 12 pcs
LINDA VELOCE (Art. 0925S)	2,5Hp / 1,9Kw, 9A	8 L	207 min ⁻¹	57x43x44 cm	85x120x193 cm

/Fittings



ART.	DESCRIPTION		
094	SHEET DISK WITH ROUNDED RIM Ø500 MM FOR FINISHING CEMENT BASES	1	5,5
097	DISK FOR ABRASIVE PAPER Ø400 MM DISK HOLDER FOR SANDING PAPER DISCS AND TUNGSTEN CARBIDE ABRASIVE DISK	1	2,8
987/1	WOLFRAM CARBIDE DISK DOUBLE FACE GRAIN 36 - Ø400 MM FOR ART. 097 FOR SANDING AND ABRADING APPLICATIONS OR LIGHT SURFACE PREPARATION	1	0,2
987/2	WOLFRAM CARBIDE DISK DOUBLE FACE GRAIN 100 - Ø400 MM FOR ART. 097 FOR SANDING AND ABRADING APPLICATIONS OR LIGHT SURFACE PREPARATION	1	0,1
0990/14	TUNGSTEN CARBIDE ABRASIVE DISK GRAIN 14 Ø400 MM DOUBLE FACE FOR ART. 097	1	0,1

LINDA
VELOCE

DO YOU WANT MORE INFO? CHECK THE BATTIPAV WEBSITE AT THIS LINK:
www.battipav.com or write us at sales@battipav.com

	ART.	DESCRIPTION		
	0990/24	TUNGSTEN CARBIDE ABRASIVE DISK GRAIN 24 - Ø400 MM DOUBLE FACE FOR ART. 097	1	0,1
	0990/36	TUNGSTEN CARBIDE ABRASIVE DISK GRAIN 36 - Ø400 MM DOUBLE FACE FOR ART. 097	1	0,1
	099	PPN BRUSH 0,80X50 Ø420 MM FOR CLEANING NARROW JOINTS FLOORS AFTER THE GROUTING	1	2,8
	096	FULL VELCRO-DRAWING DISK Ø380 MM DISK HOLDER FOR FELT DISCS	1	1,7
	982/1	BLACK FELT Ø406 MM FOR ART. 096 MUCH ABRASIVE FOR HEAVY CLEANINGS	5	1,6
	982/2	GREEN FELT Ø406 MM FOR ART. 096 ABRASIVE FOR NORMAL CLEANINGS	5	4,5
	982/3	BEIGE FELT Ø406 MM FOR ART. 096 ABRASIVE FOR SOFT CLEANINGS	5	3,5
	982/4	WHITE FELT Ø406 MM FOR ART. 096 SOFT FOR POLISHING	5	1,0
	098SP	SPONGE DRAWING DISK Ø380 MM	1	1,8
	0910/T	SPONGE FOR THE FLOORS WASHING H. 5 Ø508 MM TO EMULSIFY THE RESIDUE OF CEMENT BASE GROUT AFTER THE GROUTING PHASE	1	0,9
	0988	DISK WITH ABRASIVE DISKS	1	3,2

/Price list

ARTICLE	DESCRIPTION	PHASE	POWER SUPPLY	KG
0925S	LINDA VELOCE WITH TANK AND PPN BRUSH Ø420			23,5
 = 230V. 50/60Hz. (2Hp/1,5Kw)				

DIFFERENCE BETWEEN

MASTER LINDA

3,4 Hp / 2,5 Kw
 STRONG AND POWERFULL MOTOR



HANDLE

Handle with double safety system and with selector for 2 speeds. Fitted with protection for hands and accidental ignition.

STRUCTURE

Structure in Aluminium cast, hosting motor, handle and wheels, for an excellent rigidity of the whole set. (Ballast only for MASTER LINDA)

CLARKE TOOL CONNECTION



LINDA VELOCE

2,5 Hp / 1,9 Kw
 1 SPEED - 207 RPM



HANDLE

Handle with double safety system and 1 speed. Fitted with protection for hands and accidental ignition.

ELECTRIC MACHINES

BATTIPAV

High Performance Diamond Tools



WATCH NOW ▶



/Description

Our selection of high quality and high performance diamond tools for universal and specific cuts for stoneware and marble is finally available!

/Special cut range

- Bestever series
- Premium series

/For materials

- Marble
- Granite
- Porcelain Stoneware

/Multi cut range

- Standard series
- Economy series

/For materials

- Bricks
- Washed Gravel
- Concrete/Kerb

























ART. K230115B

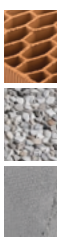

Art. K230115T

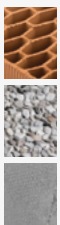
/Price list

	ARTICLE	TO CUT		QUALITY	USAGE		Ø MM	Ø HOLE MM	
	TNSB350W		Marble	SPECIAL-CUT BESTEVEER ////	 		350	25,40	
	TNSB300W		Granite				300		
	TNSB250W		Porcelain				250		
	TNSB200W		Stoneware				200		
	TNSP350W		Marble	SPECIAL-CUT PREMIUM ////	 		350	25,40	
	TNSP300W		Granite				300		
	TNSP250W		Porcelain				250		
	TNSP200W		Stoneware				200		
	TNSB125D		Marble	SPECIAL-CUT BESTEVEER ////	 		125	22,23	
	TNSB115D		Granite				115		
	TNSP125D		Marble	SPECIAL-CUT PREMIUM ////	 		125	22,23	
	TNSP115D		Granite				115		
	UNS600W		Bricks	MULTI-CUT STANDARD ////	 		600	25,40	
	UNS500W		W.Gravel				500		
	UNS400W		Concrete				400		
	UNS350W		Kerb				350		
	UNS300W						300		
	UNE230D		Bricks	MULTI-CUT ECONOMY ////	 		230	22,23	
	UNE125D		W.Gravel				125		
	UNE115D		Concrete				115		

HIGH PERFORMANCE DIAMOND TOOLS



DRILL BITS

IDEAL FOR CUTS OF: PORCELAIN GRES AND NATURAL STONE



MAX RPM
1.000 / 2.500

USE ONLY ON DRILL



COOLING WAX

- Ensure longer tool life

Art. CER18

DRILL BIT SET

- Fitted with hexagon system for optimal grip
- Fitted with wax lubrication

Art. CDSETD



GRINDER BITS

IDEAL FOR CUTS OF: PORCELAIN GRES AND NATURAL STONE



MAX RPM
10.000 / 12.000

USE ONLY ON GRINDER

M14 connection



Art. HGSETD

GRINDER BIT SET

- Fitted with hexagon system for optimal grip on the drill chuck
- Fitted with wax lubrication



/Pricelist

ART.	TECHNICAL DATA	
DRILL BITS	Diameter Ø mm	H. MAX mm
DRILL BIT (CD06D)	6	30
DRILL BIT (CD08D)	8	40
DRILL BIT (CD10D)	10	40
DRILL BIT (CD12D)	12	40
DRILL BIT SET (CDSETD)	6 / 8 / 10 / 12	35 / 40
COOL WAX LUBRICANT (CER18)	FOR DRILLS, BOX - 18 PCS	
GRINDER BITS	Diameter Ø mm	H. MAX mm
GRINDER BIT (HG06D)	6	35
GRINDER BIT (HG08D)	8	35
GRINDER BIT (HG10D)	10	35
GRINDER BIT (HG12D)	12	35
GRINDER BIT (HG20D)	20	50
GRINDER BIT (HG25D)	25	50
GRINDER BIT (HG35D)	35	50
GRINDER BIT (HG40D)	40	50
GRINDER BIT (HG55D)	55	50
GRINDER BIT (HG70D)	70	50
GRINDER BIT SET (HGSETD)	20 / 25 / 35 / 55 / 70	50
COOL WAX LUBRICANT (CER18)	FOR GRINDER, BOX - 18 PCS	

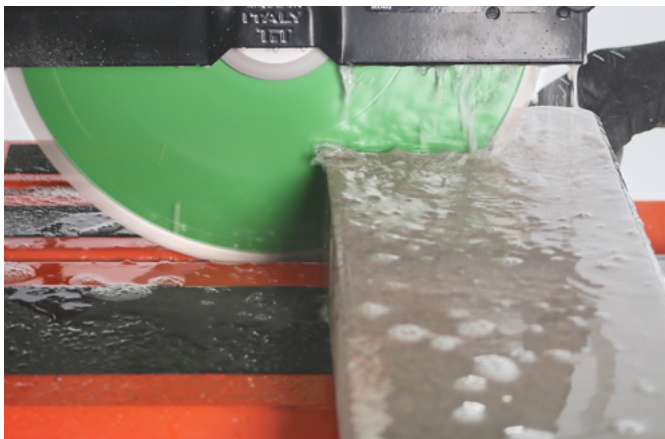



SUBMERSIBLE PUMPS

ORIGINAL WATER RECYCLING PUMP



Type Approved
Safety
Regular Production
Surveillance

www.tuv.com
ID 111128003

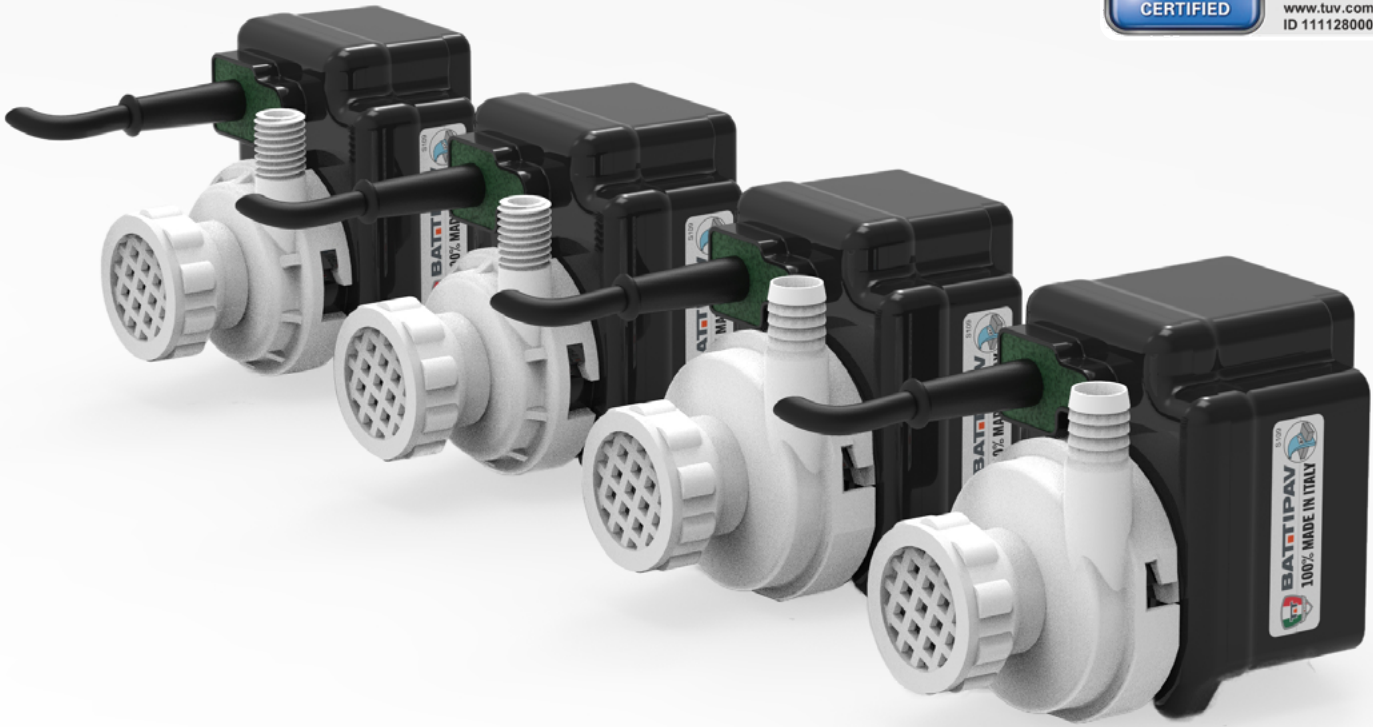

/Description

Professional submersible water pumps for water recirculation in brick-tile saw. We offer a complete range of three models which differ in the amount of water they are able to pump. All special voltages are also available.

/Caratteristiche

- All the pumps in the standard voltages have TÜV/GS approval
- Every model is subject to controls of the all the hydraulic features
- All pumps are subject to rigorous electrical testing

/Trademarks



/Range

- P0
- P1
- P2
- P3



SUBMERSIBLE PUMPS

ORIGINAL WATER RECYCLING PUMP



AXT

To better identify our submersible pumps and safeguard their quality and longevity, each product is marked with the registered trademark AxT.



ELECTRICAL TESTS

All the pumps are subject to rigid electrical quality tests.

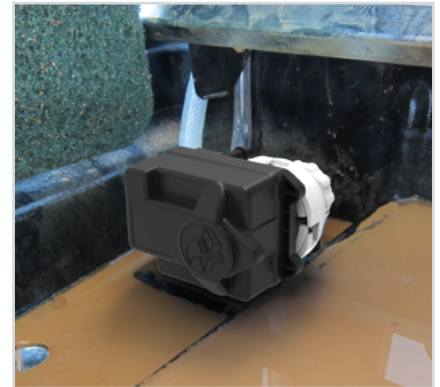

RECIRCULATION

Professional submersible water pumps used for the recirculation of the cutting disc cooling liquid.

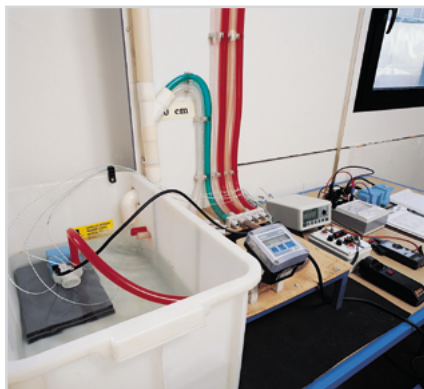

HYDRAULIC TESTS

Every model is subject to verifications of the respective hydraulic characteristics.



MADE IN ITALY

All the models are created, designed and produced in ITALY, with certified quality and patented system.



ADAPTABLE

Battipav pumps can be used with different machines and disposals, according to the size of the disk.

/Technical Info

Art.	WATT	Cable length	Isolation class:	IP grade:	Range:		H. Max		Max deep		
					230V-50hz	230V-60hz	230V-50hz	230V-60hz	230V-50hz	230V-60hz	
P3	60	2,2 mt	F	X8	1560 lt/h	1250 lt/h	2,5 mt	3,3 mt	2,5 mt	3,3 mt	19x34x28 cm
P2	55	2,2 mt	F	X8	1000 lt/h	950 lt/h	2,4 mt	3,2 mt	2,4 mt	3,2 mt	19x34x28 cm
P1	50	2,2 mt	F	X8	850 lt/h	900 lt/h	2,2 mt	3,0 mt	2,2 mt	3,0 mt	19x34x28 cm
P0	35	2,2 mt	F	X8	700 lt/h	700 lt/h	1,9 mt	2,4 mt	1,9 mt	2,4 mt	19x34x28 cm

SUBMERSIBLE PUMPS



DO YOU WANT MORE INFO? CHECK THE BATTIPAV WEBSITE AT THIS LINK:
WWW.BATTIPAV.COM/PUMPS

SUBMERSIBLE PUMPS



SUBMERSIBLE PUMPS

ORIGINAL WATER RECYCLING PUMP

/Fittings

	ART.	DESCRIPTION		
	SPS003	SUCTION SET (COMPLETE NOZZLE FOR P0/P1 + IMPELLER + O-RING)	1	0,1
	SPS203	SUCTION SET (COMPLETE NOZZLE FOR P2/P3 + IMPELLER)	1	0,1

/Price list

ARTICLE	CABLE LENGHT	VOLTAGES/FREQUENCY		KG
P0	2,20 mt	230V./50-60HZ.	12	11,9
P0/Z	2,20 mt		24	23,9
P1	2,20 mt		12	13,6
P1/4	4,00 mt		6	7,2
P1/Z4	4,00 mt		24	27,0
P2	2,20 mt	115V./50-60HZ.	12	13,6
P2/A	2,20 mt		12	13,6
P2/A4	4,00 mt		6	6,9
P2/4	4,00 mt		6	6,9
P2/Z4	4,00 mt		24	27,3
P3	2,20 mt	230V./50-60HZ.	6	8,5
P3/4	4,00 mt		6	8,5
P3/10	10,00 mt		6	9,5



CUSTOMIZABLE

Supplied with universal electrical connection for grafting into different types of machines.



MULTIPLE DISPOSAL

Possibility to rotate 90°/-90°/180°, for greater adaptability.

T LEVEL

SELF-LEVELING SPACER



/Description

Self-levelling spacers are used for laying tiles; they allow you to eliminate height differences between tiles and keeps them in a coplanar position until the glue is completely dry.

The self-leveling spacer can be used for small and large sizes and the clamp speeds up the tile installation.

/Characteristics

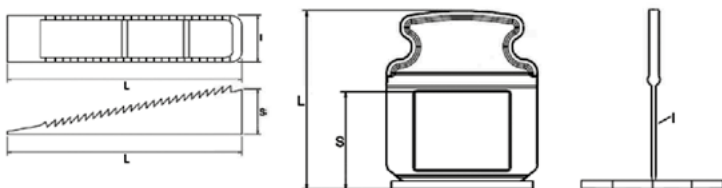



ARTICLE	MATERIAL	L (mm)	S (mm)	L (mm)
WEDGE	ABS	91,3	19	21,9
TIE-BEAM 1MM	nylon	39	21,3	1
TIE-BEAM 1,5MM	nylon	39	21,3	1,5
TIE-BEAM 2MM	nylon	39	21,3	2

Adjustment from 3 up to 12mm

T LEVEL



ART.	DESCRIPTION		
330/1	WEDGE 250 pcs.	4	2,3
331/1	TIE-BEAM 1MM 250 pcs.	10	0,7
338/1	TIE-BEAM 1,5 MM 250 pcs.	10	0,8
332/1	TIE-BEAM 2MM 250 pcs.	10	0,8
333	PLIERS FOR SELF-LEVELLING SPACER	1	0,2
336	STEEL PLIERS FOR SELF LEVELING SYSTEM	1	0,4

T LEVEL | Application System

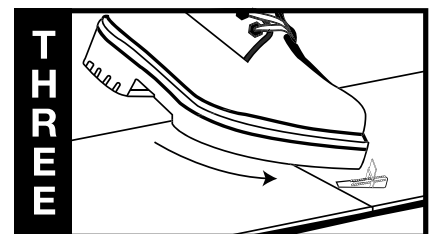
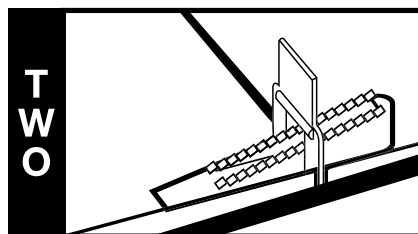
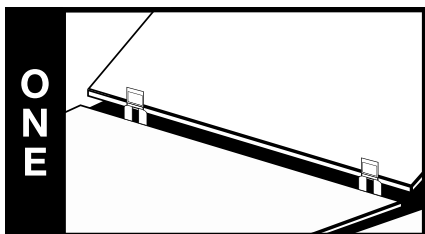





SELF-LEVELING / TOOLS

TOOLS

CERAMIC TILE LAYING TOOLS

ART.	DESCRIPTION			Euro
Mallet				
	152 WHITE RUBBER MALLET, 500 GR. Ø45 MM	15	0,7	
	153 WHITE RUBBER MALLET, 1000 GR. Ø60 MM	15	1,0	
	153/1 RUBBER MALLET, 500 GR. Ø60 MM	24	0,6	
Plastering trowel				
	904 PLASTERING TROWEL FOR FELTS WITH VELCRO ADHESIVE SIZE 235x80 MM	10	0,2	
	FELTS LOOSE FOR ART. 904 - SIZE 250x120 MM.			
	904/1 BLACK FELT, MUCH ABRASIVE	10		
	904/2 GREEN FELT, ABRASIVE	10		
	904/3 BEIGE FELT, ABRASIVE	10	0,1	
	904/4 WHITE FELT, SOFT FOR POLISHING	10		
Grouting rubber trowel				
	906 GROUTING RUBBER TROWEL FOR GROUTING FLOOR AND WALL TILES WITH CEMENT. GREY RUBBER SIZE 254x98x14 MM	10	0,4	
	906E GROUTING EPOXY RUBBER TROWEL FOR GROUTING FLOOR AND WALL TILES WITH EPOXY RESIN. LIGHT GREY RUBBER SIZE 254x98x14 MM	10	0,4	
ART.	DESCRIPTION			
Sponge trowel				
	906/1 INTERCHANGEABLE TROWEL'S HANDLE	1	0,2	
	9021ST INTERCHANGEABLE SPONGE SWEEPEX WITH CUTS HIGH ABSORPTION INTERCHANGEABLE SPONGE FOR ART. 902S	8	0,3	

TOOLS



	902ST	INTERCHANGEABLE SPONGE TROWEL SWEEPEX WITH CUTS FOR WASHING FLOORS AND WALLS AFTER THE JOINT. HIGH ABSORPTION SIZE 340x180x40 MM	14	0,5
	901ST	INTERCHANGEABLE SPONGE TROWEL SWEEPEX WITH CUTS FOR WASHING FLOORS AND WALLS AFTER THE JOINT. HIGH ABSORPTION SIZE 290x130x40 MM	24	0,4
	9011ST	INTERCHANGEABLE SPONGE SWEEPEX WITH CUTS HIGH ABSORPTION INTERCHANGEABLE SPONGE FOR ART. 901S	12	0,2
	910ST	SPONGE TROWEL SWEEPEX WITH CUTS FOR WASHING FLOORS AND WALLS AFTER THE JOINT. TOP ABSORPTION SIZE 290x130x40 MM	24	0,3
	902S	INTERCHANGEABLE SPONGE TROWEL SWEEPEX FOR WASHING FLOORS AND WALLS AFTER THE JOINT. HIGH ABSORPTION SIZE 340x180x40 MM	14	0,3
	9021S	INTERCHANGEABLE SWEEPEX MAXI SPONGE HIGH ABSORPTION INTERCHANGEABLE SPONGE FOR ART. 902S	8	0,2
	901S	INTERCHANGEABLE SWEEPEX SPONGE TROWEL SIZE 290x130x40 MM	24	0,2
Sponge trowel				
	910S	SPONGE TROWEL SWEEPEX FOR WASHING FLOORS AND WALLS AFTER THE JOINT. HIGH ABSORPTION SIZE 290x130x40 MM	24	0,4
Tray				
	926	ECO TRAY WITH TWO ROLLERS AND FOUR WHEELS	2	9,0
Sucker				
	221	SUCKER STRUCTURE IN ALUMINIUM HIGH LIFTING CAPACITY Ø120 MM	6	0,4
Glue whip				
	220	GLUE WHIP LENGTH 550 MM, Ø120 MM	6	0,3
	222	HELICOIDAL WHIP LENGTH 570 MM, Ø115 MM.	25	0,8

TOOLS



Crosses / Spacer / Wedges					
312	CROSSES 2 MM	500 PCS.		12	0,1
313	CROSSES 3 MM	500 PCS.		12	0,2
314	CROSSES 4 MM	500 PCS.		12	0,3
315	CROSSES 5 MM	500 PCS.		12	0,6
317	CROSSES 7 MM	500 PCS.		12	0,9
310	CROSSES 10 MM	500 PCS.		12	1,3
322	T-SPACERS 2 MM	500 PCS.		12	0,3
323	T-SPACERS 3 MM	500 PCS.		12	0,2
325	T-SPACERS 5 MM	500 PCS.		12	0,4
327	T-SPACERS 7 MM	500 PCS.		12	0,7
309	WEDGES	1000 PCS.		12	0,5

BRICKLAYER AND PLASTERERS TOOLS

ART.	DESCRIPTION			Euro
Sponge				
917	SEMICIRCULAR CELLULOSE SPONGE SIZE 190x50x80 MM	50	0,1	





OCEANIA

	ART.	DESCRIPTION	FREQUENCY/VOLTAGE		
VIP	AUS850	Vip 260****	230v./50hz.	1,3Hp / 1,0Kw 4,5A / 2800rpm	
	AUS855	Vip 290****	230v./50hz.	1,3Hp / 1,0Kw 4,5A / 2800rpm	
	AUS856	Vip 2110 *****	230v./50hz.	1,3Hp / 1,0Kw 4,5A / 2800rpm	
	AUS857	Vip 2125*****	230v./50hz.	1,8Hp / 1,4Kw 6A / 2800rpm	
CLASS	AUS65901	Class 900S, Aus Plug And Handle *	230v./50hz.		
	AUS651101	Class 1100S, Aus Plug And Handle*	230v./50hz.		
	SP90259/AUS	Schuko Socket 230v + Cable 3 Mt. ****			
	SP90159/AUS	Cee Socket 230v + Cable 3 Mt. *****			



SWITZERLAND

	ART.	DESCRIPTION	FREQUENCY/VOLTAGE		
ELITE	CH9001	Elite 80S, With Current Limiter*	230v./50hz.	3,0Hp / 2,2Kw 9A / 2800rpm	
PRIME	CH91201	Prime 120S , With Current Limiter*	230v./50hz.		
	CH91501	Prime 150S, With Current Limiter*	230v./50hz.		





SAUDI ARABIA AND U.A.E.

	ART.	DESCRIPTION	FREQUENCY/VOLTAGE		
ELITE	9001/CS1	ELITE INFINITY 80S 1 PHASE*	230V./60HZ.		
	SP90159/UK	CEE SOCKET 220V. + CABLE 3MT.+ UK PLUG			

* With Laser And Wheels / **With Laser / ***With Wheels/****With Whip and Bucket / *****With Australian Plug / ***** With Australian Plug and Handle

UNITED KINGDOM



	ART.	DESCRIPTION	FREQUENCY/VOLTAGE		
PRIME	90851/A	Prime 85S*	115v./50hz.	3,0Hp / 2,2 Kw 16A / 2800rpm	
	91001/A	Prime 100S*	115v./50hz.		
	91201/A	Prime 120S*	115v./50hz.		
	91501/A	Prime 150S*	115v./50hz.		
	92001/A	Prime 200S*	115v./50hz.		
ELITE 	9001/A	Elite 80S*	115v-50hz.	3,0Hp / 2,2 Kw 16A / 2800rpm	
SUPREME	80851/A	Supreme 85S*	115v./50hz.	3,0Hp / 2,2 Kw 16A / 2800rpm	
	81001/A	Supreme 100S*	115v./50hz.		
	81201/A	Supreme 120S*	115v./50hz.		
	81501/A	Supreme 150S*	115v./50hz.		
	82001/A	Supreme 200S *	115v./50hz.		
CLASSplus	66901/A	Class Plus 850S*	115v./50hz.	1,8Hp / 1,4 Kw 12A / 2800rpm	
	661101/A	Class Plus 1050S*	115v./50hz.		
	661351/A	Class Plus 1300S*	115v./50hz.		
CLASS	65671/A	Class 670S*	115v./50hz.	1,3Hp / 1,0 Kw 8,7A / 2800rpm	
	65901/A	Class 900S*	115v./50hz.		
	651101/A	Class 1100S*	115v./50hz.		
	SP0502/ACEE	Extension Cable 10 Mt. With Cee Plug & Socket 115v. (Suitable For Class Range 115v With Laser)			
VIP	850/A	Vip 260 Disk Ø 200 C/C	110v./50hz.	1,3Hp / 1,0 Kw 8,7A / 2800rpm	
	855/A	Vip 290 Disk Ø 200 C/C	110v./50hz.		
	856/A	Vip 2110 Disk Ø 200 C/C	110v./50hz.		
	857/A	Vip 2125 Disk Ø 250 C/C	115v./50hz.	1,8Hp / 1,4 Kw 12A / 2800rpm	
	GB857	Vip 857, Uk Plug	230v./50hz.		
	GB856	Vip 856, Uk Plug	230v./50hz.	1,3Hp / 1,0 Kw 4,5A / 2800rpm	
	GB855	Vip 855, Uk Plug	230v./50hz.		
	GB850	Vip 850, Uk Plug	230v./50hz.		
EGO+PLUS	8000/J/A	E..Go Plus	115v./50hz		
Mixer	050S/A	Mixer 50 Super ***	115v./50hz.	1,6Hp / 1,2 Kw 12A / 55rpm	
	P2/A4	Water Pump P2, Cable 4mt	115v./60-50hz		
	P2/A	P2 Water Pump	115v./50-60hz.		
	SP90159/A	Cee Socket 110v. + Cable 3 Mt. + Cee Plug 110v			

* With Laser And Wheels / **With Laser / ***With Laser / ****With Wheels/****With Whip and Bucket

CENTRAL AND NORD AMERICA

	ART.	DESCRIPTION	FREQUENCY/VOLTAGE		
Mixer	USA050S/B	MIXER 50 SUPER, US PLUG	115V./60HZ.	1,6Hp / 1,2 Kw 12A / 74rpm	
VIP	USA850/B	VIP 260, US PLUG + 1 DISK TNSB200W	115V./60HZ.		
	USA855/B	VIP 290, US PLUG	115V./60HZ.	1,3Hp / 1,0 Kw 8,5A / 3400rpm	
	USA856/B	VIP 2110, US PLUG	115V./60HZ.	1,3Hp / 1,0 Kw 8,5A / 3400rpm	
	USA857/B	VIP 2125, US PLUG	115V./60HZ.	1,8Hp / 1,4 Kw 11,5A / 2800rpm	
CLASS	USA65901/B	CLASS 900S, US PLUG *	115V./60HZ.	1,3Hp / 1,0 Kw 8,5A / 3400rpm	
CLASSplus	USA66901/B	CLASS PLUS 850S , US PLUG *	115V./60HZ.		
	USA661101/B	CLASS PLUS 1050S, US PLUG *	115V./60HZ.	1,8Hp / 1,4 Kw 12A / 3400rpm	
	USA661351/B	CLASS PLUS 1300S, US PLUG *	115V./60HZ.		
	USA70241	EXTENSION SIDE BENCH FOR DYNAMIC/CLASS CM 74 - INCH			
EXTRA SUPERLUNGA	USA6733001/B	EXTRA 3300 SUPERLUNGA, US PLUG + 4 SIDE TABLES *	115V./60HZ.	1,8Hp / 1,4 Kw 12A / 3400rpm	
SUPREME	USA81201/B	SUPREME 120S, WITH CABLE AND US PLUG *	115V./60HZ.		
	USA81501/B	SUPREME 150S, US PLUG*	115V./60HZ.		
	USA82001/B	SUPREME 200S, US PLUG *	115V./60HZ.	3,0Hp / 2,2 Kw 16A / 3400rpm	
	USA82601/B	SUPREME 260S, US PLUG*	115V./60HZ.		
	USA83201/B	SUPREME 320S, WITH CABLE AND US PLUG *	115V./60HZ.		
EGO+PLUS	USA8000J/B	EGO PLUS, US PLUG	115V./60HZ.	3,0Hp / 2,2 Kw 16A / 3400rpm	
ELITE	USA9001/B	ELITE 80S, US PLUG *	115V./60HZ.	3,0Hp / 2,2 Kw 16A / 3400rpm	
	9001/CS1	ELITE INFINITY 80S	230V./60HZ.	3,0Hp / 2,2Kw 10,5A / 3400rpm	
PERFECT jolly	USA11401	PERFECT JOLLY Ø 115 5/8 - 11			
Profi^{EVO}	USA6401EV	PROFI EVO 45			
	USA6601EV	PROFI EVO 63			
	USA6850EV	PROFI EVO 88			
	USA61000EV	PROFI EVO 103			
	USA61300EV	PROFI EVO 133			
	USA61600EV	PROFI EVO 163			
SINTESI	USA40093	SINTESI 93			
	USA40133	SINTESI 133			
	USA40163	SINTESI 163			
	USA40183	SINTESI 183			
	SP90259/USA	CEE SOCKET 110V + CABLE 2,5 MT. + USA PLUG			

* With Laser And Wheels / **With Laser / ***With Wheels / ****With Whip and Bucket

SV + PLUG



40
YEAR
ANNIVERSARY
1983 - 2023
BATTIPAV

FOLLOW US



Z. i. 2 - Via Cavatorta, 6/1 | 48033 Cotignola (Ra) | ITALY | Tel. +39 0545 40696
www.battipav.com